



USER MANUAL FOR CNES ZERO PRESSURE BALLOONS



	Name/Acronym:	Date and Signature
Prepared by	S. Louvel DSO/BL	 19/01/2018
Validated by	A. Vargas DSO/BL	 30/01/2018
Application authorised by	V. Dubourg DSO/BL/D	 01/02/2018

Applicability to Aerostat Systems (tick the systems concerned):

BSO (ZPB)	BPS	MIR	BPCL	AEC
X				

Applicability to projects (tick the projects concerned):

STRATEOLE-2	PILOT	FIRBL	BSO-REVOL	EUSO
	X		X	X

Document configuration-managed: YES / ~~NO~~ by: Balloon Management Committee (CCM) as from: 19/01/2018

CHANGES

Version	Date	Purpose
1.0	13/03/2013	Initial version in 3 volumes
2.0	04/12/2017	<p>Updating the 3-volume version:</p> <p><u>Volume: 1</u></p> <ul style="list-style-type: none"> Change Request (DM) 5242, taking the new auxiliary balloons into account. DM 5327, concerning the landing speed under parachutes. <p><u>Volume: 2</u></p> <ul style="list-style-type: none"> DM 5355, taking the PASTIS modules into account. <p><u>Volume: 3</u></p> <ul style="list-style-type: none"> Change Request (DM) 5242, taking the new auxiliary balloons into account. DM 5327, concerning the landing speed under parachutes. DM 5355, taking the PASTIS modules into account. DM 6586, concerning the PLG positioning of the PASTIS WiFi antenna Updating the radioelectric specifications (§2.4). Adding Chapter 4 on the standard instrumentation of the flight train. Reformulation of Requirement 30300 about dropsounding during "light" flights. Adding of Requirement 30400 on airdrops during "heavy" flights.
3.0	19/01/2018	<p>DM 6586, concerning the positioning of the PASTIS WiFi antenna on the PLG (payload gondola).</p> <ul style="list-style-type: none"> Grouping of all 3 User Manuals (MUs) into a single volume. Recasting of the chapters of the MU (all §§). Updating the information on campaign organisation (§2). Updating the information on the certification process (§3). Grouping of PASTIS characteristics (§1.3). Additions on the instrumentation available during flight (§1.4). Additions on the temperature data at the different sites (§4.5). Addition of the results of the ONERA report on radiation levels (§4.6). Distinguishing the requirements applicable to instruments (§5). Reformulation of the requirement EX-0-MNU-00800 (§5.1.2). Addition of the term "regulatory" in requirement EX-0-MNU-01300 (§5.1.4). Taking "Other Risks" into account in certification (§5.3). Presentation of the PLGs and their associated services (Appendix). <p>The processing of DM 6733 concerning the specification for lateral accelerations acting on PLGs during separation will be consolidated following the analysis of the measurements made during the 2018 STRATO SCIENCE campaign.</p>

CONTENTS

INTRODUCTION	7
PURPOSE	7
GLOSSARY AND ABBREVIATIONS	7
1. PRESENTATION OF THE ZPB SYSTEM	9
1.1. Introduction.....	9
1.2. The ZPB system.....	9
1.2.1. On-board segment.....	10
1.2.2. Ground segment.....	11
1.2.3. Operational resources	11
1.3. Telecommunication interfaces	12
1.3.1. General presentation of the network	12
1.3.2. Scientific Interfaces / Ground PASTIS Module.....	13
1.3.3. Managing the stream of science data	14
1.3.4. Archiving.....	14
1.3.5. Internet access	14
1.3.6. Characteristics of the PASTIS modules	14
1.4. Sensors carried on board the PLGs (payload gondolas).....	16
2. THE ZPB CAMPAIGN.....	17
2.1. Description of typical missions.....	17
2.2. Preparatory phase	18
2.2.1. Safety submission phase.....	18
2.2.2. Logistical phase.....	18
2.2.3. Mission analysis phase.....	18
2.3. Operational phase	18
2.3.1. Operational coordination	18
2.3.2. Kick-off meeting	18
2.3.3. AIT of the PLG	19
2.3.4. Weather forecast briefing	19
2.3.5. Flight phase	19
2.3.6. Recovery phase.....	21
2.3.7. Closure meeting.....	21
3. THE CERTIFICATION PROCESS.....	22
3.1. Technical analysis of the mission.....	22
3.1.1. Definition.....	22
3.1.2. Certification analysis.....	22
3.2. The Technical Questionnaire.....	22

3.2.1.	The flight	22
3.2.2.	Gondola or instrument	23
3.2.3.	Specific requests	23
3.2.4.	Make-up of the team.....	23
3.2.5.	Personal Protective Equipment (PPE)	23
3.2.6.	Launch countdown	23
3.3.	Risk mitigation	23
3.3.1.	Balloon safety requirements	24
3.3.2.	Risk identification and mitigation	24
3.4.	Quality, Safety, Environment (QSE)	25
3.5.	Documentation summary.....	26
4.	THE BALLOON ENVIRONMENT	26
4.1.	When the envelope masks the direct solar flux.....	26
4.2.	Masking cone	27
4.3.	Solar radiation.....	27
4.3.1.	Direct solar flux	27
4.3.2.	Albedo.....	28
4.4.	Infrared radiation	29
4.5.	Air pressure and temperature.....	30
4.6.	Radiation	31
4.7.	Shedding ballast.....	33
5.	CERTIFICATION REQUIREMENTS	33
5.1.	Mechanical specifications	33
5.1.1.	Interfaces between the PLG and the ZPB system	34
5.1.2.	Mechanical stress	39
5.1.3.	Temperatures	43
5.1.4.	Transport	43
5.2.	Electrical and radioelectric risks.....	44
5.2.1.	Risk of fire.....	44
5.2.2.	Risk of electric shocks	44
5.2.3.	Risk of breakdown	44
5.2.4.	Systems subject to risk.....	45
5.2.5.	Labelling	45
5.2.6.	Frequency plan	45
5.3.	Other risks.....	46
5.3.1.	List of items at risk.....	46
5.3.2.	Labelling	47
APPENDIX:	PAYLOAD-CARRYING GONDOLAS AVAILABLE	49

FIGURES

Figure 1: System Architecture with broadband link.....	9
Figure 2: Breakdown of a ZPB aerostat	10
Figure 3: Schematic representation of the NOSYCA ground segment	11
Figure 4: Testing and configuring the pair of PASTIS modules	12
Figure 5: Communications link during flight.....	13
Figure 6: Dimensions of the on-board PASTIS module	15
Figure 7: Dimensions of the auxiliary on-board PASTIS module	16
Figure 8: Effect of short-wavelength flux on the upper part of the gondola	27
Figure 9: Solar constant, with examples of the density of direct solar flux in the atmosphere.....	28
Figure 10: Examples of values for albedo coefficients and albedo flux density in clear skies for a ground albedo coefficient of 0.8 (fresh snow).....	29
Figure 11: Densities of rising and descending infrared radiation obtained in clear skies	30
Figure 12: Air temperatures derived from the ECMWF's ERA-Interim reanalyses.....	31
Figure 13: Clearance of the upper and lower interfaces of the PQUA	34
Figure 14: Configurations with double interface	35
Figure 15: Positioning of the MRDI \varnothing 12 links interfacing with the PLG.....	35
Figure 16: The dimensional characteristics of an MRDI \varnothing 12 link.....	36
Figure 17: Configuration of the single interface, with an MRNI \varnothing 14 link interfacing with the PLG .	36
Figure 18: The dimensional characteristics of an MRNI14 link	37
Figure 19: Maximum altitude as a function of the weight of the PLG in a standard atmosphere	38
Figure 20: Acceleration spectral density of vibration loads.....	41
Figure 21: Examples of impact indicators RECORDA-G, OMNI-G and MAG 2000	42

List of Things to Be Confirmed/Determined

TBC/TBD	Section	Title	Action
TBD	5.1.2	DM 6733 concerning the specification for lateral accelerations acting on PLGs during separation	BL/NB
TBD	Appendix	Presentation of the CNES gondolas and their associated services – to be completed (Carmencita, new services, etc.)	BL/NB

Documentation

Applicable Documents:

DA1: RNC-CNES-R-ST-12-01	Flight safety regulations for balloon activities Volume: 1 Risk control requirements
DA2: RNC-CNES-R-ST-12-02	Flight safety regulations for balloon activities Volume: 2 Design and operating rules

Reference Documents:

DR1: CAM-QT-[campaign]-[PLG]-[lab]	ZPB technical questionnaire
DR2: NOSYCA-MU-PASTIS-10358-CN	User and Integration Manual PASTIS/PLG

INTRODUCTION

The Balloon Sub-Directorate at the Toulouse Space Centre is responsible for flying aerostats on behalf of CNES, in France and abroad. As such, it is responsible for the equipment and facilities used, and for the safety of people, property and the environment in which this activity is performed.

PURPOSE

This manual is intended for scientific laboratories or industrial companies that have requested a zero pressure (stratospheric) balloon flight. Its purpose is to present ZPB missions and the rules applying to this type of flight.

This document only deals with payload gondolas (PLGs) consisting of a principal payload and any secondary (piggy-back) payloads in a single payload gondola.

Any mission must follow the process laid out in this document before being submitted to CNES for flight authorisation.

GLOSSARY AND ABBREVIATIONS

Acronym	Definition
Aerostat	An aircraft whose lift is due to the thrust obtained (Archimedes Principle) by the inflation of an envelope with a gas that is less dense than the surrounding atmosphere. In the framework of ZPBs, the term includes all flight components. The aerostat consists of the balloon and the flight train.
AIT	Assembly, Integration, Tests
APR	<i>Appel à proposition de Recherche</i> (Call for research proposals)
ARGOS	Worldwide satellite system for the location and collection of geolocated data
ATC	Air Traffic Control.
Balloon	The balloon refers to all the parts of the aerostat located above the separation level. It consists of the envelope, valve(s), the envelope gondola (NEV) and the upper part of the main separator.
Barrier	Anything installed to prevent the occurrence of an event that could compromise safety is referred to as a barrier. A safety barrier may be a physical property, an intrinsic design characteristic, a technological device, and exceptionally a mandatory procedure.
BAX	<i>Ballon AuXiliaire</i> [Auxiliary balloon]. An auxiliary balloon is a balloon filled with a gas lighter than air, whose purpose is to support the PLG during the launch phase.
BLEST	<i>Bac à lest</i> (ballast compartment) The ballast compartment is a flight control element for storing ballast and releasing it on demand during the flight, in order to lighten the aerostat. In the ZPB system, the BLEST forms part of the NSO (operational servitude gondola).
BSO (ZPB)	Zero-Pressure Balloon (<i>Ballon Stratosphérique Ouvert</i>) A zero-pressure balloon is a balloon filled with a gas lighter than air and whose internal pressure at the bottom of the balloon is identical to the atmospheric pressure. Because of its large volume and its proportionally very light structure, it is capable of reaching the stratosphere.
CC	<i>Centre de Contrôle</i> [Control centre]
CDV	<i>Chaîne De Vol</i> (flight train) The flight train comprises all the elements of the aerostat located under the separation level and that return to the ground under parachute(s) after the separation (as such, it includes the lower part of the main separator).
CICLOP	<i>Centre Informatique de Contrôle pour le Lancement OPérationnel</i> (Computerised control centre for operational launches) This is the NOSYCA CC.
CNES	<i>Centre National d'Etudes Spatiales</i> [French Space Agency]
CST	<i>Centre Spatial de Toulouse</i> [Toulouse Space Centre]
DA	<i>Document Applicable</i> [Applicable document]
DR	<i>Document de Référence</i> [Reference document]
Envelope	Sealed film defining a volume, usually axisymmetric, almost entirely closed, which contains the lift gas and ensures the buoyancy of the aerostat. The envelope is completed by polar

	parts at its apex and base. It can be fitted with accessories such as an electrical harness, an inflation tube, etc.
Flight	A flight begins when the aerostat is released and ends with the landing of all the components of the aerostat.
FMECA	Failure Modes, Effects and Criticality Analysis
Gondola	Generic term defining a mass element, usually rigid, that fulfils a specific function as part of the aerostat.
GPS	Global Positioning System. American satellite positioning system
ITAC	<i>Interface de Télé Acquisition et de Contrôle</i> (Remote Acquisition and Command Interface)
MIR	<i>Montgolfière InfraRouge</i> Hot air balloon functioning with atmospheric thermal fluxes
MRDI	Maillon Rapide Delta Interface
MRNI	Maillon Rapide Normal Interface
NEV	<i>Nacelle Enveloppe</i> . The Envelope Gondola, containing the balloon's control equipment and attached directly to the balloon.
NFAE	<i>Nacelle Feu A Eclat</i> . A small autonomous gondola containing a strobe light.
NOSYCA	<i>NOuveau SYstème de Contrôle d'Aérostats</i> . A project aiming to develop a new system for the command & control of aerostats (applicable to several balloon families). For ZPBs, this project concerns onboard command gondolas (NSO, NEV and NFAE), the ground station (SCILA), the ground segment (CICLOP) and the onboard and ground PASTIS modules.
NOTAM	NOTice To AirMen
NSO	<i>Nacelle de Servitude Opérationnelle</i> (Operational flight control/housekeeping gondola). Gondola fulfilling most of the aerostat's control functions, located in the flight train under the parachute.
PASTIS	<i>PASserelles Technologiques d'Interface Science</i> (science interface technology gateways)
Payload	The scientific or operational equipment carried by the aerostat.
PI	Principal Investigator. The PI is the person with overall responsibility for a scientific or technology experiment on behalf of a laboratory or a company.
PLG (NCU)	Payload Gondola (<i>Nacelle Charge Utile</i>). Gondola containing the mission payload. It is usually located in the lower part of the suspended assembly. There is no PLG in the BSO ReVol project.
PPE	Personal protection equipment
PPU	<i>Point de Panne Unique</i> (single point of failure)
PQUA	<i>Point QUADruple</i> (quadruple point attachment)
PTU	Pressure, Temperature, HUmidity.
QSE	Quality, Safety, Environment
SCC	Stress corrosion cracking.
SIRSE	<i>Système Iridium de Suivi d'Enveloppe</i> (Iridium envelope tracking system) This is the control module on the NEV of the ZPB system.
Suspended assembly	All the parts of the aerostat suspended under the balloon hook. It includes the parachute(s), the flight control equipment, mechanical components and the PLG.
TBC	To be confirmed
TBD	To be defined
TC	<i>Télé Commande</i> (Remote control)
TM	Telemetry
TQ	Technical Questionnaire
ULIS	<i>Unité Légère d'Interface Satellitaire</i> (Lightweight Satellite Interface Unit)
Valve	Device located at the apex of the balloon that can be opened to release lift gas.
VP	<i>Véhicule Porteur</i> (carrier vehicle) This assembly consists of the envelope and the valve(s), if any. If there is no valve, the carrying vehicle consists of the envelope alone.

1. PRESENTATION OF THE ZPB SYSTEM

The ZPB system encompasses all the on-board and ground resources needed for a ZPB science mission carried out during a flight.

1.1. INTRODUCTION

NOSYCA is the new onboard-ground system used by CNES ZPBs to comply with flight safety rules while optimising the resources to be implemented to achieve these ends.

NOSYCA offers scientists the possibility of:

- a communications link between their instruments and the scientific ground segment during the flight;
- configuring their network architecture themselves;
- integrating payload gondolas (PLGs) while taking the constraints of flight/ground data-rates into account.

1.2. THE ZPB SYSTEM

The ZPB system comprises:

- an on-board segment;
- a ground segment (TM/TC station, control centre, mission centre);
- corresponding operational means (AIT, launch and recovery of the aerostat, weather forecasts and mission analyses, logistical resources, power supply, telecom network).

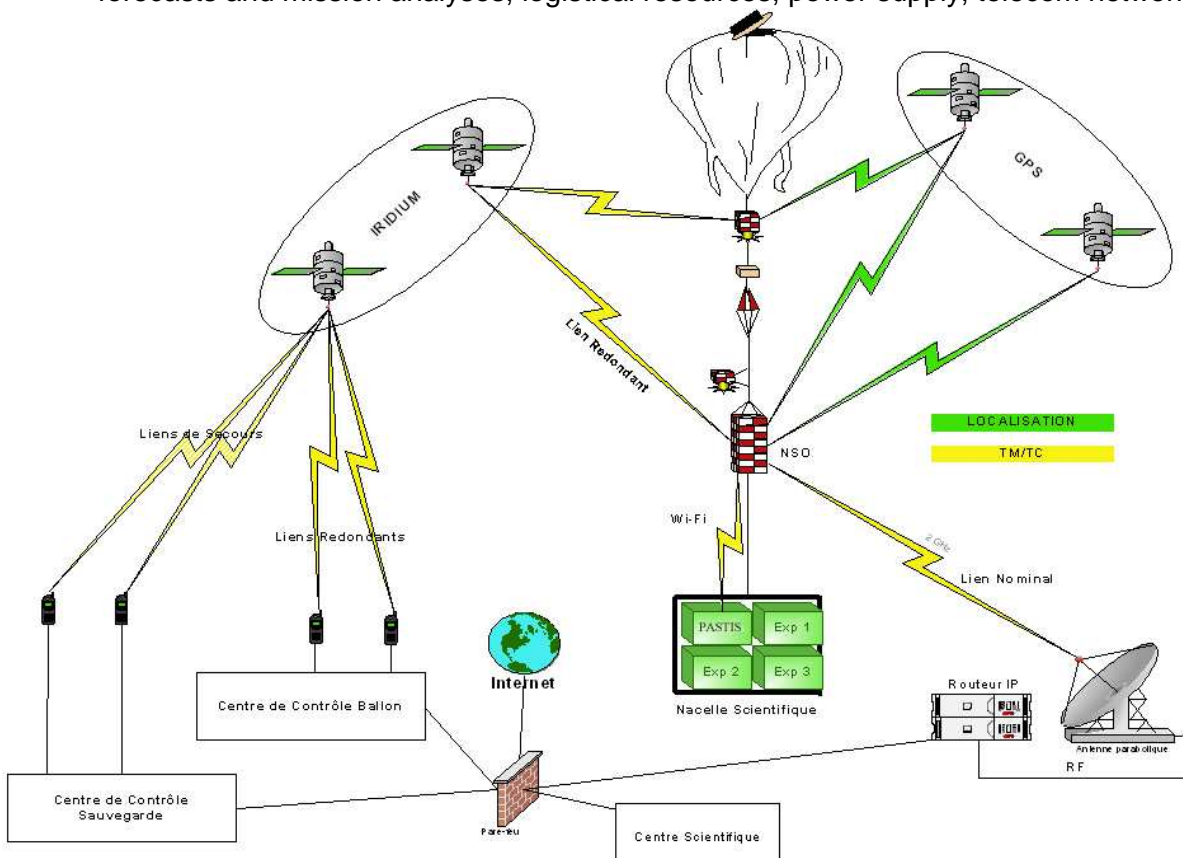

Figure 1: System Architecture with broadband link

1.2.1. ON-BOARD SEGMENT

The breakdown of the on-board segment (a ZPB aerostat) is as follows:

- Balloon
 - ⇒ VP (lifting vehicle)
 - Valve
 - Enveloppe (including harness)
 - ⇒ NEV
 - SIRSE
 - NEV Mechanical interface
- Flight train
 - ⇒ Main separator
 - ⇒ Parachute system
 - ⇒ NSO
 - BLEST
 - ITAC
 - ULIS
 - ⇒ NFAE
 - ⇒ Flight train (straps)
 - ⇒ Auxiliary balloon
 - ⇒ PLG with possibility of communication via PASTIS

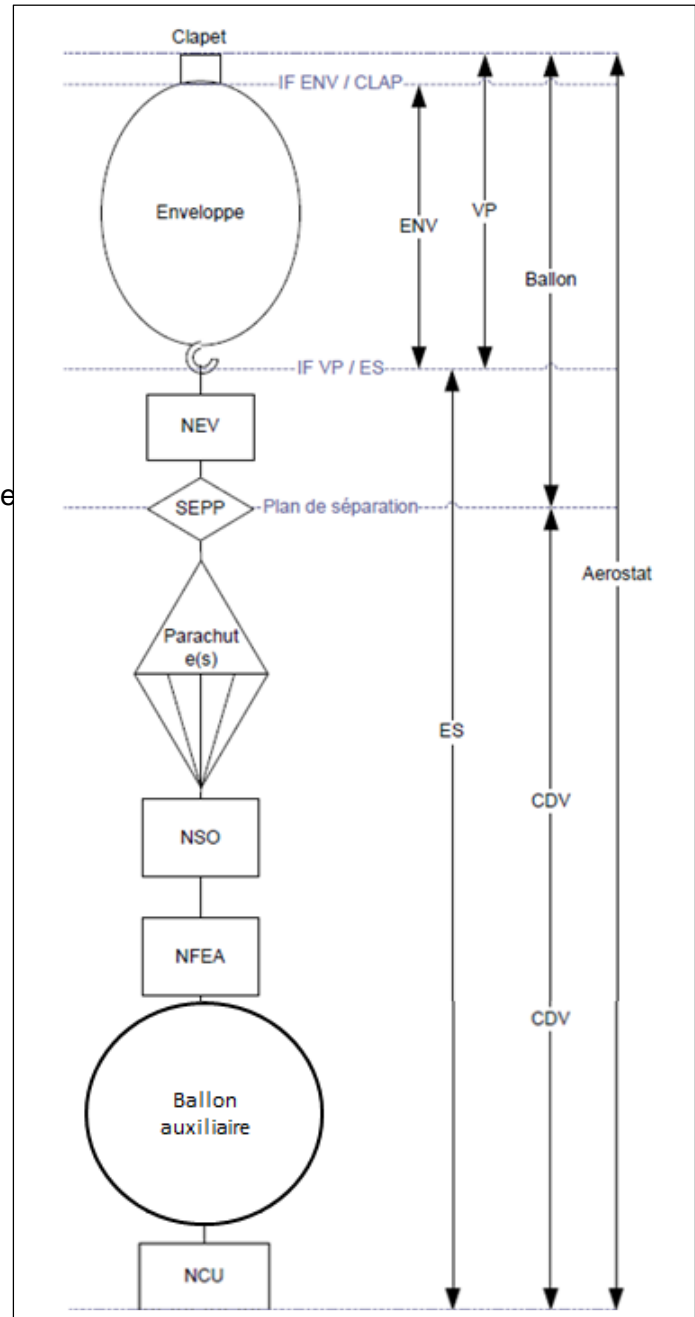

Figure 2: Breakdown of a ZPB aerostat

The PLG is part of the on-board segment, but is not part of the ZPB system.

1.2.2. GROUND SEGMENT

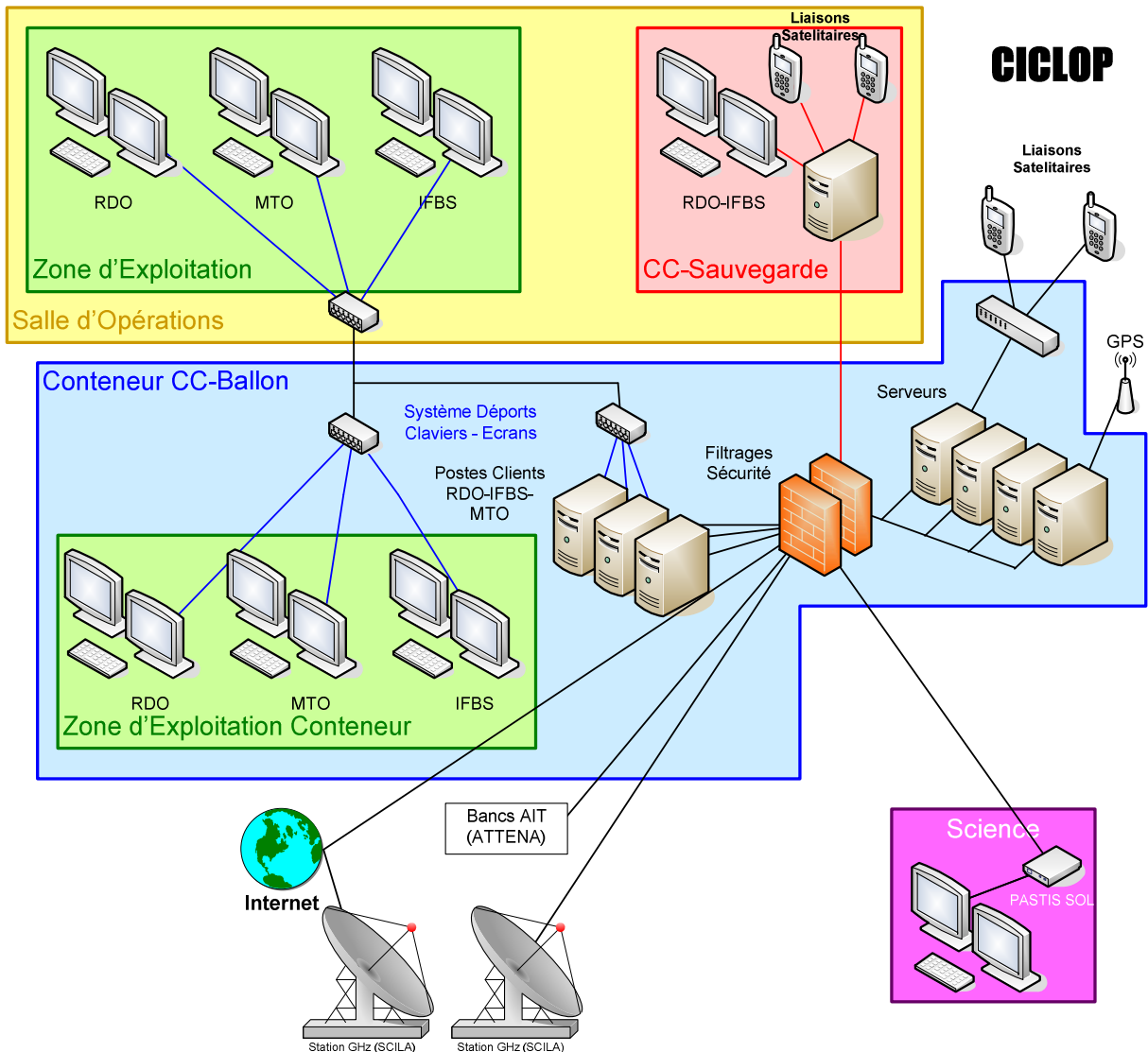

Figure 3: Schematic representation of the NOSYCA ground segment

1.2.3. OPERATIONAL RESOURCES

CNES's operational resources consist of:

- Launch resources:
 - ⇒ a system for maintaining the tension of the flight train;
 - ⇒ a winch vehicle interfacing between the auxiliary balloon (BAX) and the flight train above the PLG;
 - ⇒ a spool release mechanism;
 - ⇒ protective tarpaulins;
 - ⇒ a BAX capable of supporting the PLG before the main balloon takes over;
 - ⇒ an inflation system.

- Resources for operations support:
 - ⇒ meteorological resources (radiosondes, access to models, etc.);
 - ⇒ power, plus backup power systems;
 - ⇒ transport and handling equipment;
 - ⇒ NOSYCA AIT resources;
 - ⇒ Internet access.

In addition, CNES has a launch area and buildings at the campaign site for preparing and integrating scientific payload gondolas and flight trains with flight control equipment.

CNES makes the following on-site services available to scientists:

- a working space in the payload integration hall, for preparing and testing PLGs;
- handling resources: a hoist in the hall and a trolley for transporting PLGs;
- power in the integration hall and at the launch zone;
- Internet access;
- access to meteorology data.

1.3. TELECOMMUNICATION INTERFACES

The PASTIS communication interfaces consist of two modules in the NOSYCA network architecture, one at each end of the scientific IP link. These modules are designed for communication between the ground and the on-board equipment and to enable the network to be configured quickly and easily. There is one PASTIS module on board, interfaced with the scientific equipment, and another on the ground, interfaced with the mission centre.

The stream of scientific data is sent via an IP tunnel, which means that the ground PASTIS module sends all TC data leaving the mission centre's processors to the on-board PASTIS module via an IP tunnel. The on-board PASTIS module then restores the same TC format as was used on input to the ground PASTIS module. For Telemetry data, the same principle applies between the on-board and the ground PASTIS modules. The system thus operates by combining a pair of PASTIS modules specifically configured for a mission.

The PASTIS modules will be configured by CNES to match the addressing plans sent by PIs when responding to the Technical Questionnaire (see DR1).

1.3.1. GENERAL PRESENTATION OF THE NETWORK

The science link is prepared in two stages:

1. Test of compatibility between the on-board and ground PASTIS modules and the PLG, independently of the NOSYCA network. This step is designed to ensure that all the science links are compatible with the PASTIS modules provided by CNES. During this test, the bandwidth of each experiment requiring communication via PASTIS will be verified to ensure that total volume of communications at any given time do not exceed the available bandwidth.



Figure 4: Testing and configuring the pair of PASTIS modules

- Once the compatibility test has proved successful, a system test of the whole science link is carried out through the NOSYCA network (including the 2GHz SCILA station) and the NSO. This is done to check that the bandwidth is divided up in the most economical way between the different experiments. It is representative of the communications link conditions during flight. This test is rerun formally during the End-to-End system test, nominally 1 to 2 days before the launch.

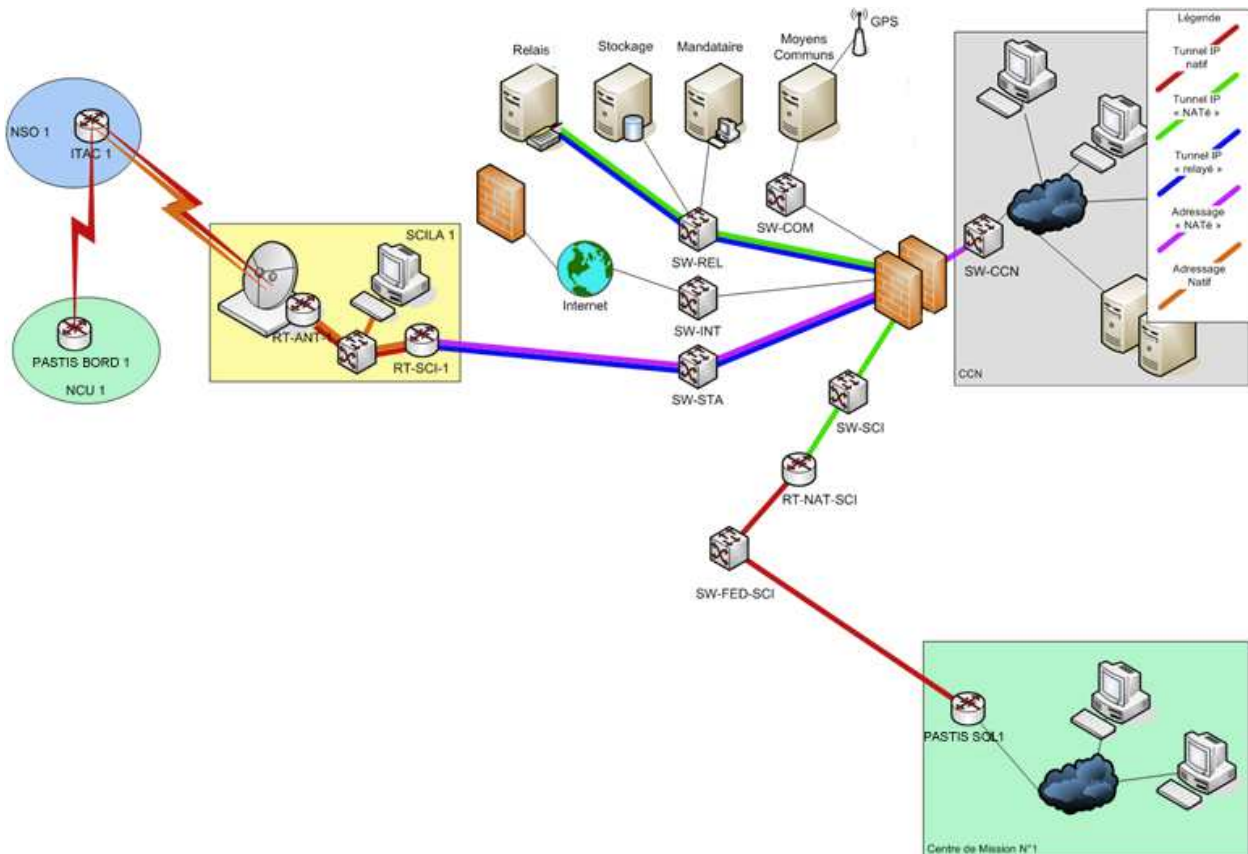

Figure 5: Communications link during flight

This configuration corresponds to the configuration implemented during the countdown and then during the flight. The link between the PLG and the mission control centre is relayed through an S-band ground station (SCILA).

NB: During transfer from the integration area to the launch zone, there may be interruptions in the link, depending on the location of the launch site.

1.3.2. SCIENTIFIC INTERFACES / GROUND PASTIS MODULE

The ground PASTIS module enables all TCs from the scientific mission control centre to be sent to the on-board PASTIS module. Conversely, it handles transmissions toward the scientific mission control centre of all TM from the on-board PASTIS module, via the network. The details of the technical characteristics of the on-board and ground PASTIS modules, as well as the interface specifications, are given in DR2.

The ground PASTIS module interfaces with:

- the on-board PASTIS module by Ethernet or via the NOSYCA network;
- the mission centre via Ethernet.

1.3.3. MANAGING THE STREAM OF SCIENCE DATA

1.3.3.1. Remote Control

The system transmits the science TCs to the on-board experiment payloads.

The scientific TCs generated on the launch site can be transmitted to the system via any of the different links available on the ground PASTIS with the following characteristics:

- Maximum useful ground/on-board data rate < 70 kb/s, guaranteed during station visibility.
- IP tunnel via PASTIS router.

The uplink bandwidth specified is the maximum bandwidth allocated for all the experiments on the PLG. The PI is responsible for ensuring that the on-board experiments comply with this constraint.

In the event of a mission being interrupted prematurely because of a failure of the on-board/ground broadband link, the PLG architecture must include a function for the PLG to be switched automatically to a landing configuration.

NB: The IS security (SSI) constraints of the NOSYCA network prohibit the use of scientific TCs developed on a site other than the operations site via Internet.

1.3.3.2. Telemetry

Scientific TM data are transmitted and made available to ground-based user systems on the launch site, with the following characteristics:

- maximum useful data rate < 1.5 Mb/s, guaranteed during station visibility.
- IP tunnel via PASTIS router.

The downlink bandwidth specified is the maximum bandwidth allocated for all the experiments on the PLG. The PI is responsible for ensuring that the on-board experiments comply with this constraint. If it is exceeded, the on-board/ground science communication system becomes saturated.

Nominally, the SSI constraints of the NOSYCA network prohibit the distribution of scientific TM data to users on a site other than the operations site via Internet.

1.3.4. ARCHIVING

If the 2 GHz RF link between the NSO and SCILA is lost, observability and control of the scientific payloads will be lost. As the PASTIS modules do not archive TC and TM data, each experiment must take this constraint into account.

1.3.5. INTERNET ACCESS

If the site's Internet access is restricted, the ground PASTIS module enables the computers at the mission control centre to access the Internet via the firewall of the ground segment with a data rate of at least 1 Mb/s. In such an event, operations will have to be coordinated with CNES to avoid saturating the communications channel.

1.3.6. CHARACTERISTICS OF THE PASTIS MODULES

1.3.6.1. ON-BOARD PASTIS

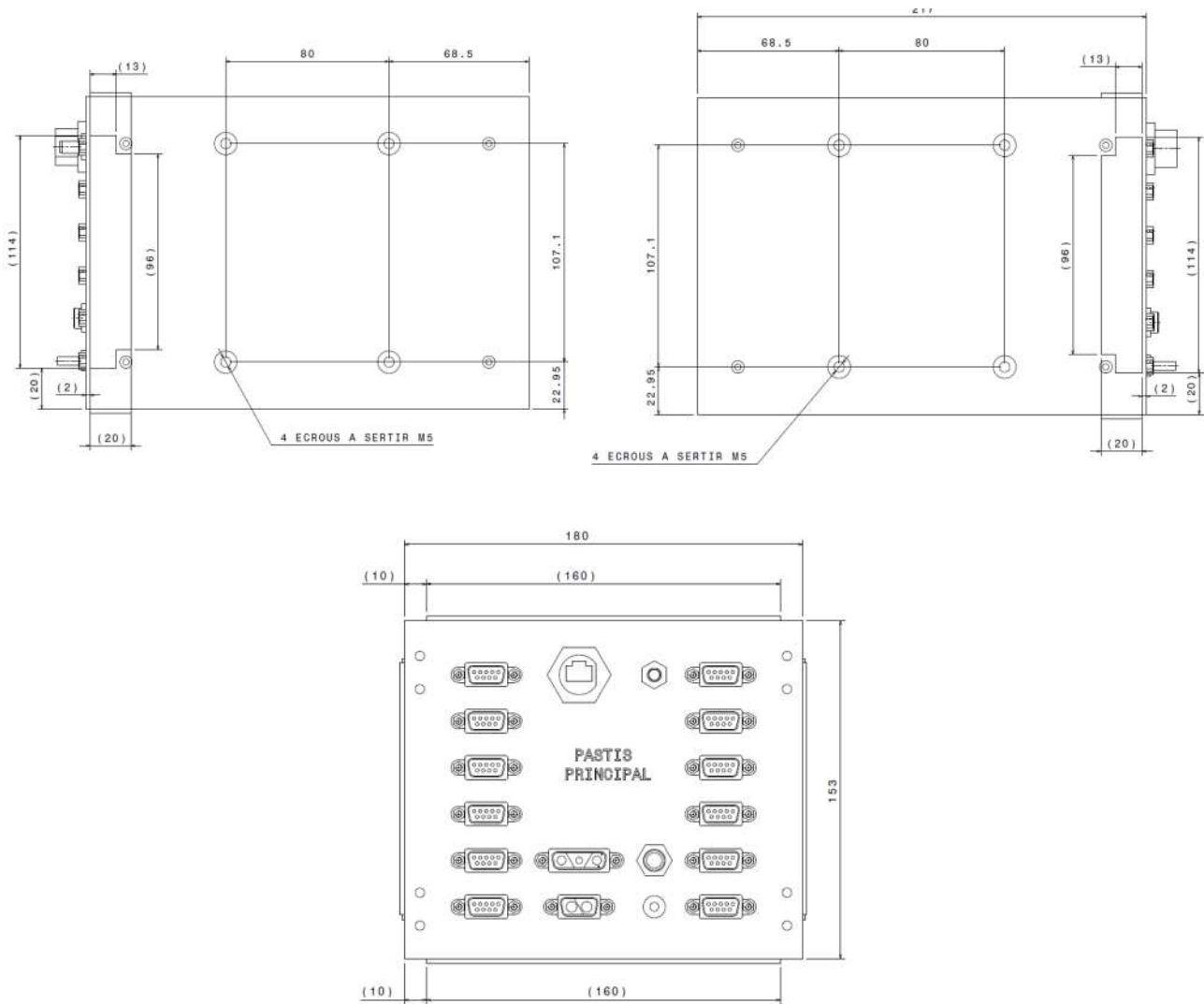
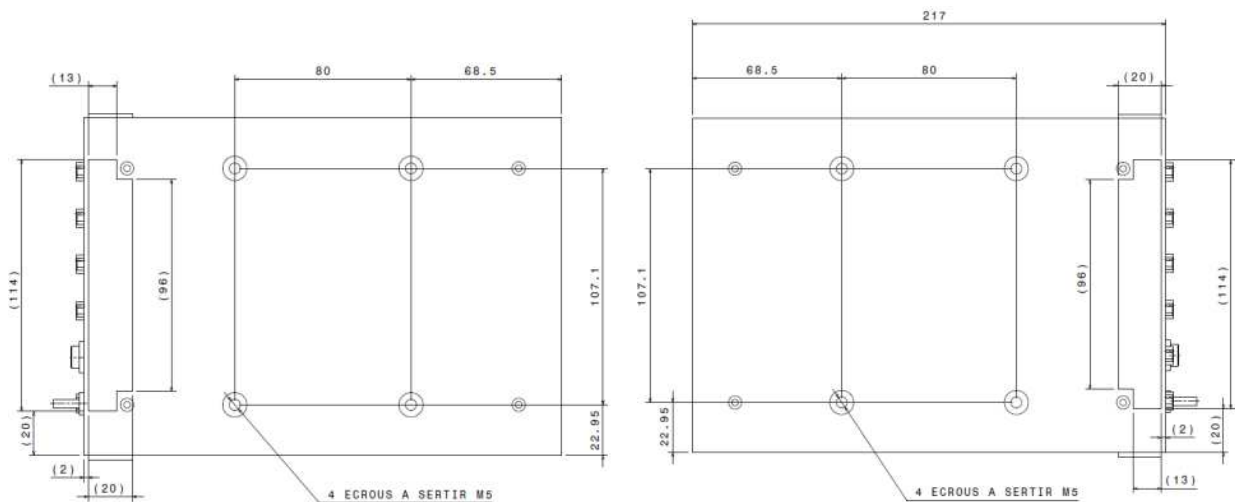

Figure 6: Dimensions of the on-board PASTIS module



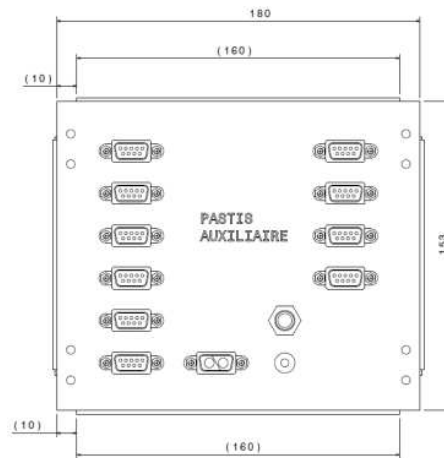

Figure 7: Dimensions of the auxiliary on-board PASTIS module

The main functions of the on-board PASTIS are:

- to provide an Ethernet link and bandwidth for scientific TM/TC between the NSO and the PLG;
- to provide 6 Ethernet links to the PLG. The number of links is reduced to 5 if the auxiliary PASTIS is used, as one of the links is used for communication between the two on-board PASTIS modules;
- to provide 12 STOR outputs to the PLG, at 35VDC/0.5 A.

The capacity of the on-board PASTIS can be increased by adding an auxiliary on-board PASTIS, with the following main functions:

- to provide 4 asynchronous two-way links (RS232/422/485) to the PLG.
- to provide 5 additional Ethernet links to the PLG (giving a total of 10 Ethernet links available for science).

1.3.6.2. GROUND PASTIS

The ground Pastis is a stand-alone router with a power supply. It can also be combined with an IP/Serial gateway. The external interfaces are:

- 8 RJ-45 Ethernet ports: only ports 6 to 10 are available for scientists. The other ports are reserved by CNES for the following connections:
 - Port 3 is used in the flight configuration to provide a connection between the mission control centre and the on-board PASTIS module via the NOSYCA science switch.
 - Port 4 is reserved for the direct link between the on-board and the ground PASTIS modules (configuration during gondola integration).
 - Port 5 is reserved for the NOSYCA ground manager for analysis of network data streams.
- If the auxiliary on-board PASTIS module is used, one of the user ports is assigned for setting up the Ethernet/series gateway. It can be used to connect 8 serial RS232/422/485 ports.

1.4. SENSORS CARRIED ON BOARD THE PLGS (PAYLOAD GONDOLAS)

All PLGs are equipped with several environmental sensors. The purpose of the on-board instrumentation is to collect measurements to better understand the environment and the behaviour of the aerostats during all phases of flight.

The following types of data are collected systematically:

- mechanical (accelerations).
- videos.

The PLG carries the following sensors:

- a 200g 3-axis accelerometer such as the MSR 165, with an acquisition frequency of 400Hz.
- a 15g 3-axis accelerometer such as the MSR 165, with an acquisition frequency of 400Hz.
- a camera with a 40° medium angle lens oriented upwards to observe the entire flight train. Video is recorded in 1080p at 30 frames per second.

If a payload is suspended under the PLG, it is equipped with the following sensors:

- a 200g 3-axis accelerometer such as the MSR 165, with an acquisition frequency of 400Hz.
- a 15g 3-axis accelerometer such as the MSR 165, with an acquisition frequency of 400Hz.

Each of these instruments carries its own power source, is unobtrusive and records its data on an internal storage device.

The choice of equipment and its configuration can of course be adapted to meet the specific needs of the mission. In addition to the standard instrumentation, some additional sensors can be carried (feasibility to be examined on a case-by-case basis):

- temperature sensors.
- pressure sensors.
- in-line load cells.
- inertial measurement unit.
- microphone.

The measurements acquired in flight can be made available to clients (request to be made at the post-flight closure meeting).

2. THE ZPB CAMPAIGN

The CNES Mission Manager is responsible for organising and running the campaign. As such, he/she is the direct contact person for the laboratories or manufacturers taking part in the campaign for both the preparatory and operational phases.

2.1. DESCRIPTION OF TYPICAL MISSIONS

Zero-pressure balloons (ZPBs) are used by CNES to carry scientific payloads weighing between a few tens and several hundred kilograms to altitude ceilings between the lower limit of the stratosphere (approximately 180 hPa) and approximately 1 hPa. (Balloon pilots habitually use pressure as a vertical coordinate.)

Consequently, the ZPB system is not designed for only one particular mission, but as a multi-mission system. It is able to perform missions such as those described above or more specific missions such as those with pointed gondolas (for scientific missions requiring pointing in azimuth and elevation of one or more instruments in a given direction), for durations of a few hours to a few days.

2.2. PREPARATORY PHASE

2.2.1. SAFETY SUBMISSION PHASE

The safety submission phase begins several months before the campaign. This aspect is the responsibility of the Mission Manager with a view to obtaining authorisation for the campaign from CNES and, ultimately, flight authorisation from the host country.

The safety requirements concerning the PLG and the on-board scientific instruments are detailed in this document in the section entitled "Certification Requirements".

2.2.2. LOGISTICAL PHASE

When a launch is performed abroad, CNES has to prepare the launch equipment, ship it to the chosen base and install it. All this equipment must be checked beforehand and must correspond to the various aerostatic configurations that will be implemented during the campaign.

The equipment is transported in 20-foot long shipping containers and amounts to a total of approximately 100 tonnes for each campaign.

The scientific or technology equipment can use the same transport system from the Aire-sur-l'Adour site to the country of destination, subject to their availability matching the CNES schedule. In this case, the laboratories or manufacturers must complete the bills of lading in customs format a few weeks before the shipping date. Hazardous materials must be declared in the bill of lading and must be provided in containers suitable for international maritime transport.

It should be noted that CNES does not take responsibility for outsize transport (of volumes exceeding the dimensions of a 20-foot long shipping container).

If equipment is not available on the dates planned by CNES, the PI can organise transport by air to reduce the shipping time. In this case, the laboratory or manufacturer is responsible for customs duty and clearance formalities. It is advisable to seek information beforehand about air transport conditions for accumulators and batteries, depending on their characteristics.

Installation of CNES equipment on the site takes about a week.

Dismantling of operational equipment takes 3 to 5 days and the return transport of the containers is organised to Aire-sur-l'Adour. The scientific equipment is kept available at the site for the laboratories or manufacturers, or may be removed by a haulier.

2.2.3. MISSION ANALYSIS PHASE

Before the campaign, mission simulations are carried out for various flight profiles in order to predict the trajectories of the candidate gondolas and their projected landing zones, in particular to ensure compliance with the safety requirements.

These simulations, based on climate data, also help to plan the dates for the campaign and to define a provisional order for individual flights.

2.3. OPERATIONAL PHASE

2.3.1. OPERATIONAL COORDINATION

The activities are organised by the Mission Manager at daily coordination meetings with the PI, CNES systems managers and the local authorities (for overseas campaigns).

2.3.2. KICK-OFF MEETING

The Kick-off Meeting is a formal meeting organised by the Mission Manager after the arrival of the PI and his team at the campaign site. It is held between the PI and CNES with local authorities attending. It precedes the start of operations at the campaign site.

The purpose of this meeting is to formally acknowledge, excluding unexpected events, that all elements of the Technical File (mission profile, PLG configuration, etc.) have been taken into account.

The most recent information concerning constraints concerning resources, safety, security and weather forecasts (both by the PI and by CNES) is imparted at the meeting. These details particularly concern scheduling for finalising PLG integration.

The Kick-off Meeting confirms the positioning of the flight within the provisional operational campaign schedule. Significant unexpected events that affect the campaign are indicated in the schedule (in the case of any change in the date of the flight).

Following the meeting, the Minutes are signed jointly by the PI and CNES, including the Charter for Use of the NOSYCA Network.

2.3.3. AIT OF THE PLG

The duration of the PLG's AIT phase (especially integration, connection and testing of the on-board PASTIS module) depends on the gondola and the complexity of the instrument. Following this PLG AIT phase, it is necessary to allow for 1 to 2 days of testing with the NOSYCA system.

Following these trials and the final weighing of the PLG, the gondola is declared fit to fly.

The arrival of the scientific team on the site is planned jointly, depending on the projected position of the flight in the campaign's flight schedule and of the duration of the complete PLG AIT process.

If equipment is to be installed on a CNES gondola, CNES personnel may assist the scientists or manufacturers in assembling and installing their experiment payload.

If the gondola has been developed by a laboratory or manufacturer, CNES will only intervene for integration of the on-board PASTIS communication module and its antenna on the gondola.

2.3.4. WEATHER FORECAST BRIEFING

Every day, a weather forecast briefing is organised at the launch base by CNES's weather forecasters. Weather conditions are analysed on the ground and higher up in the atmosphere to ensure that launch and trajectory conditions are acceptable.

These results are presented to all the persons concerned by the flight or flights studied and representatives of the local authorities (in the case of missions abroad).

At the end of this meeting, if the operational system is ready and the mission and safety criteria are met, the Mission Manager authorises the flight. After this, the decision to fly falls to the PI, who assesses the state of preparedness of the instruments (flight readiness) and whether the proposed mission is fit to go ahead.

2.3.5. FLIGHT PHASE

2.3.5.1. Launch countdown

This phase begins with a Go/NoGo briefing including a weather forecast of ground conditions for the duration of the countdown period and on the latest trajectory forecasts. The purpose is to confirm the mission and safety conditions before pronouncing the start of flight preparation operations.

The countdown activities involve deploying the aerostat system (including the Control Centre and the means for monitoring the flight) before launching the aerostat and finalising the flight configuration of the PLG's instruments. This also covers the periods for inflating the envelopes (auxiliary balloon, then the main envelope). This phase lasts between 3 and 5 hours and ends with the launch of the balloon.

2.3.5.2.Countup

- ***Aerostat launch phase***

This phase begins with the triggering of the release mechanism (H_0 of the flight) and the gradual rise of all elements of the flight train until the PLG itself is suspended. The operations manager ensures that all the equipment organs for positioning and for communicating with the aerostat are functioning correctly.

- ***Aerostat ascent phase***

This phase follows the launch phase, with the main envelope rising in altitude, carrying with it the suspended assembly, at a mean vertical speed of 5 to 6 m/s. If the aerostat is launched with an auxiliary balloon (BAX), the latter's envelope is attached to the lower part of the flight train by a mechanical device. The BAX is released a few seconds before the main balloon takes up the weight. Once the BAX is aligned with the flight train, an evacuation tube at its apex releases the gas. The envelope remains attached to the aerostat throughout the flight.

From this phase onwards, the aerostat can be controlled (opening/closing the balloon valve, releasing ballast) in order to navigate the transitions between the various atmospheric layers as smoothly as possible, and to optimise the ascent manoeuvres to reach the ceiling. Because the aerostat passes through flight corridors, it carries transponders to enable Air Traffic Controllers (ATCs) to track it, and a Notice to Airmen (NOTAM) must be issued to indicate its presence.

Full ascension may take between 1 and 3 hours, depending on the size of the balloon and the altitude of the ceiling sought for the mission.

- ***Float phase, with (or without) variations in altitude***

This is the main mission phase. The aerostat system has carried the payload to the altitude planned for the start of the mission and the aerostat can be controlled to follow the flight profile requested by the scientists. If required, this phase may include one or more slow descent phases.

Ballast release manoeuvres affect the behaviour of the balloon, and possibly any measurements being made. Advance notice of ballast release will be transmitted and managed by the operational coordination team at the launch site. As the ballast tray is located on the NSO, ballast release may cause steel beads to fall onto the PLG. Advance notice therefore enables the scientists to activate protection or safety procedures for the most vulnerable equipment.

During the flight, the aerostat system must maintain communication links between the flight and ground segments for controlling the aerostat and its position, and for the needs of the scientific users.

This phase lasts from a few hours to a few tens of hours.

In flight, the system can transmit the predicted trajectory as well as one or more simulated trajectories. Requests by the scientists for trajectory simulations during operation, in order to optimise the mission profile, will be coordinated by the operations team.

- ***Separation phase***

This phase puts an end to the flight according to end-of-mission criteria and/or of safety criteria. It may be necessary to continue the flight after the mission phase for safety reasons, or even to cut a mission short if required by safety constraints.

CNES is responsible for deciding when the flight has officially ended.

- ***Phase for deflating the envelope***

Following activation of the system for separating the envelope from the suspended assembly, the envelope is ripped open at the seams into four sections, to release all the gas and end the flight of the envelope as rapidly as possible.

The envelope takes 20 or 30 minutes to descend to the ground.

- ***Descent phase***

Following the separation between the envelope and the suspended assembly, the two elements are treated independently. The suspended assembly descends under one or more parachutes, as part of the flight train.

The positioning systems of these two mobile elements are constantly operational to ensure aviation safety and enable them to be recovered.

The suspended assembly takes 30 to 50 minutes to reach the ground. at a mean vertical speed of about 6 m/s on landing.

2.3.6. RECOVERY PHASE

2.3.6.1. Aerostat securing phase

This phase is defined case by case, as a function of the countries overflown and the predicted landing areas.

The final locations of the two objects (envelope and suspended assembly) once on the ground are transmitted from the operations room to the security teams (or to the authorities responsible for this activity for flights abroad) so that they can go directly to the sites.

2.3.6.2. Aerostat recovery phase

On the basis of drift forecasts during the parachute descent, the recovery teams can take up positions in advance to enable them to locate the PLG rapidly (this usually takes at least 2h to 6h) if necessary for scientific or security reasons.

The recovery teams transfer the elements onto suitable vehicles for return to the launch site. It may happen that this phase cannot be carried out until several hours after the landing. During the kick-off meeting, the scientific team must provide the procedure for configuring the PLG for transport back to the launch base.

The duration of this phase depends on the landing site and the time of year: it can vary from a few hours to 3 days.

2.3.7. CLOSURE MEETING

Following the flight and recovery of the PLG, the Mission Manager organises a closure meeting on site with the PI of the flight concerned, the CNES system managers and the local authorities. The purpose is to hold a post-flight debriefing of the campaign, including the countdown and count-up, the flight and the recovery operations.

The meeting is recorded in Minutes.

3. THE CERTIFICATION PROCESS

At the beginning of each year, CNES issues a Call for Research Proposals (*Appel à Proposition de Recherche*, or APR), which has several sections, including the annual list of ZPB campaign opportunities for the years n+1 and n+2. If a proposal is selected by the joint CNRS/CNES Technical Committee on Balloons (CTB) and accepted by the Steering Committee, CNES includes the flight in one of the campaigns it is currently preparing.

3.1. TECHNICAL ANALYSIS OF THE MISSION

3.1.1. DEFINITION

Once a proposal is selected, the laboratory or the manufacturer requesting the flight must complete a technical questionnaire and return it to CNES (see DR1).

On the basis of this information and for the purpose of certification, CNES analyses the following points:

- the feasibility of the flight as a function of its technical and logistical possibilities;
- compliance of the experiment with the standards and rules in force;
- ensuring that there are no unacceptable risks during the implementation of the system, including in degraded cases.

3.1.2. CERTIFICATION ANALYSIS

3.1.2.1. Complete procedure

A PLG or an instrument to be certified at CNES for the first time can only be qualified after CNES has analysed and accepted the technical documents. If CNES approves the documentation provided by the scientific team or the manufacturer it will include it in the certification file.

Before each flight, CNES reserves the right to check that the gondola assembly complies with the definition documents provided by the PI and to inspect in particular the components of the gondola's suspension system, as well as how they are assembled.

3.1.2.2. Simplified procedure

A payload is considered to be qualified if its configuration complies with one that has been accepted by the certification authority for a previous CNES flight. The best way of proving compliance is to create a logbook listing all changes to the gondola between flights.

In any case, CNES will check the compliance of the mechanical configuration before the flight.

3.1.2.3. Certification schedule

The Technical Questionnaire and file grouping all the elements necessary for certification of the PLG or of an instrument must be provided to the CNES at least **6 months** before the start of the campaign.

3.2. THE TECHNICAL QUESTIONNAIRE

The purpose of the Technical Questionnaire (TQ – see DR1) is to identify the Principal Investigator (PI) and to explain the experiment, what it seeks to achieve, and the constraints concerning its implementation. The TQ must be submitted to the CNES Mission Manager, whose contact details are indicated on the title page.

The main themes addressed in the TQ are listed in the following sections.

3.2.1. THE FLIGHT

This is where PIs should give specific details about payloads and the necessary flight characteristics. The flight profile must be defined and the flight configuration of the gondola must be described.

If there are any weather constraints, these should be clearly stated. Finally, if soundings are necessary, their type and frequency should be specified.

The real-time communication needs for TM/TC between the aerostat and the ground segment should also be specified, in compliance with the characteristics listed in Section 1.3.

3.2.2. GONDOLA OR INSTRUMENT

The gondola's, or the instrument's, mechanical and electronic characteristics should be described, as well as the characteristics of telecommunications streams.

The following components must be listed and all data concerning them provided:

- structural elements;
- pyrotechnical elements;
- pressurised tanks,
- toxic substances;
- inflammable substances;
- emission of ionising radiation;
- emission of electromagnetic radiation;
- emission of laser radiation.

If the flight train includes a system for pivoting the suspended assembly, this must be reported and taken into account in the mechanical design documents for the gondola.

3.2.3. SPECIFIC REQUESTS

Any specific needs must be clearly stated for the experiments concerning pointing, protection, power supply, transport, and the need for specialists to intervene during the different phases, from integration to recovery.

3.2.4. MAKE-UP OF THE TEAM

Each participant must be identified, together with their parent organisations.

3.2.5. PERSONAL PROTECTIVE EQUIPMENT (PPE)

PPE is mandatory and each scientific team is responsible for providing PPE for its own staff.

3.2.6. LAUNCH COUNTDOWN

An indicative countdown timeline is provided in the TQ for specifying the main steps in the successive activities. If any specific operations are required before or during this countdown sequence, they must be clearly defined.

3.3. RISK MITIGATION

This section highlights the requirements applicable to PLGs and instruments carried on CNES's BOS aerostats. The purpose of these requirements is to demonstrate to CNES that PLGs comply with safety regulations for balloon activities (see DA1 & DA2).

These requirements are applicable to all the instruments and gondolas that can be carried on a CNES ZPB aerostat.

The risks concerning the safety of the aerostat assembly, people and property must be identified and mitigated.

3.3.1. BALLOON SAFETY REQUIREMENTS

3.3.1.1. Requirements

Risk levels are defined in the safety regulations according to the following degrees of severity:

Catastrophic	Loss of human life.
Serious	Serious injury to people, significant damage to property or to the environment.

Mitigating these risks requires the specification of qualitative safety requirements.

No **single failure** (hardware failure, software error, human error...) shall involve a risk of catastrophic consequences.

For this reason, two safety barriers must be installed to counter catastrophic risks.

3.3.1.2. Application to PLGs

As for any part of the aerostat, the PLG must not be subject to risks leading to catastrophic consequences following a single failure. The regulations concerning payload safety are expressed by the requirements listed in Chapter 5 of this document.

Thus, the PI must:

- ensure that PLG faults cannot propagate to the rest of the aerostat or, if this is not possible, characterise these risks (electrical risks for the interfaces, etc.) to ensure that they are mitigated at the system level;
- ensure that the fastening point(s) at which the PLG and any other mechanical components are attached to the flight train is/are sufficiently strong;
- ensure that the mountings of the instruments carried in the PLG are sufficiently robust;
- ensure that the PLG is placed in a safe configuration.

To guarantee that these risks have been taken into account, the PI is required to carry out the analyses presented below.

3.3.2. RISK IDENTIFICATION AND MITIGATION

3.3.2.1. Control of fault propagation from the PLG to the aerostat

To control the risk of fault propagation, the PI is requested to submit a Failure Modes and Effects Analysis (FMEA) for the elementary components of the interfaces between the PLG and the aerostat.

The purpose of this analysis is to ensure that no single failure of the PLG, or its components, can disrupt the proper functioning of the aerostat.

If any single-failure points (PPU) remain, these must be clearly identified and the need for dealing with them, substantiated to CNES (acceptance, if they can be de-activated at system level, or possibly, a request for waiver).

3.3.2.2. Robustness of mechanical elements connecting the PLG to the flight train

In order to comply with the certification regulations, it is necessary to ensure that the fastening point(s) at which the PLG and any other mechanical components are attached to the flight train cannot break. The means for attaching instruments must be designed to withstand the expected accelerations.

These risks are mitigated by including a safety margin in the mechanical design calculations for all mechanical components under the environmental conditions to which the aerostat may be subjected. The margins must be equivalent to those taken for sizing the aerostat's passive mechanical elements (straps, links, hook, etc.).

Mechanical analyses must be performed or tests carried out to verify that all elements are sized correctly.

3.3.2.3. Safety analysis

The PI must identify all risks threatening the safety of people and property, based on a hazard analysis of the instrument or of the PLG proposed for the flight.

A form for typical risks and a matrix for identifying the risks can be found in Appendices 2 & 3 of the TQ (see DR1). They include the identification and classification of risks and the measures taken to reduce catastrophic or serious risks.

To complete the risk identification matrix and risk forms, one simply indicates whether or not there is a risk (A for Applicable, N/A for Non-Applicable) and describes any risk succinctly (instrument concerned, etc.). The science team must complete a risk sheet (Appendix 3) for each risk identified in the matrix.

3.3.2.4. Mitigating risks related to jettisoning elements

If experiment payloads require jettisoning elements of the PLG during flight phases (e.g. pressure, temperature and relative humidity – PTU – sensors, etc.) the PI must analyse the lethality of the elements to be dropped. The jettisoning system will automatically be considered to be a critical element and must therefore be included in the safety study.

The feasibility of the mission is subject to the permissions to jettison being granted by the country or countries overflown. CNES takes responsibility for issuing and following up requests for authorisations to jettison as part of the requests for overflight authorisations.

3.4. QUALITY, SAFETY, ENVIRONMENT (QSE)

The QSE instructions are applicable to any person involved in the mission and are laid out clearly in the prevention plan.

The CNES QSE department ensures the safety of people, the protection of the environment and the continuous improvement of procedures in this field. It also ensures that personnel are trained to use the equipment, which must be implemented under its normal conditions of use. It also ensures compliance with the standards and regulations in force for the following areas of application: the safety of people and respect for the environment.

For this purpose, it undertakes a risk analysis that takes into account an analysis of risk to the PLG itself but also to broader aspects such as:

- transport;
- medical and health aspects;
- emergency services and repatriation;
- normal living conditions;
- working conditions and organisation;
- risks related to the individual and joint activities of personnel from different companies;
- risks of impact on the environment;
- the security of the mission site.

A prevention plan is drawn up on the basis of this risk analysis, depending in part on the launch site, with the aim of preventing all possible risks to personnel involved in the mission.

This prevention plan, supervised by the Mission Leader, must be accepted by the participants at the start of the campaign, who thus undertake to abide by it throughout the mission.

3.5. DOCUMENTATION SUMMARY

Every PI is requested to produce:

- a completed technical questionnaire with its related documents at least 6 months before the start of the campaign;
- a "PLG security report" comprising the above-mentioned analyses, demonstrating that all identified risks are being mitigated. Any un-mitigated risk should be clearly identified and will require a request for waiver to be submitted to the Director of the CST;
- a compliance matrix regarding requirements of this document;
- if the gondola has already flown, the post-flight mechanical inspection report.

4. THE BALLOON ENVIRONMENT

4.1. WHEN THE ENVELOPE MASKS THE DIRECT SOLAR FLUX

The envelope of the balloon is semi-transparent in the same spectral band as solar radiation. Its position relative to the gondola and the sun can cause partial or total masking of the direct solar flux onto the gondola. The balloon may also be a source of stray light reflections.

The measurements carried out by the solar irradiance sensors (pyranometers) during the THEMIS flight (launched on 22 July 1990, a 900Z balloon, see figure below) showed the very clear effect of masking caused by the balloon when the Sun was at its zenith. This disturbance is characterised by an abrupt change of irradiance flux when the balloon is between the Sun and the gondola. When the Sun is hidden by the balloon, we observe a bell curve, explained by the impact of the direct solar flux on the envelope.

NB: The observed phenomenon depends on the relative positions of the Sun, the balloon and the gondola, and has different consequences depending on the flight configurations, the launch site and the time of year the balloon is launched.

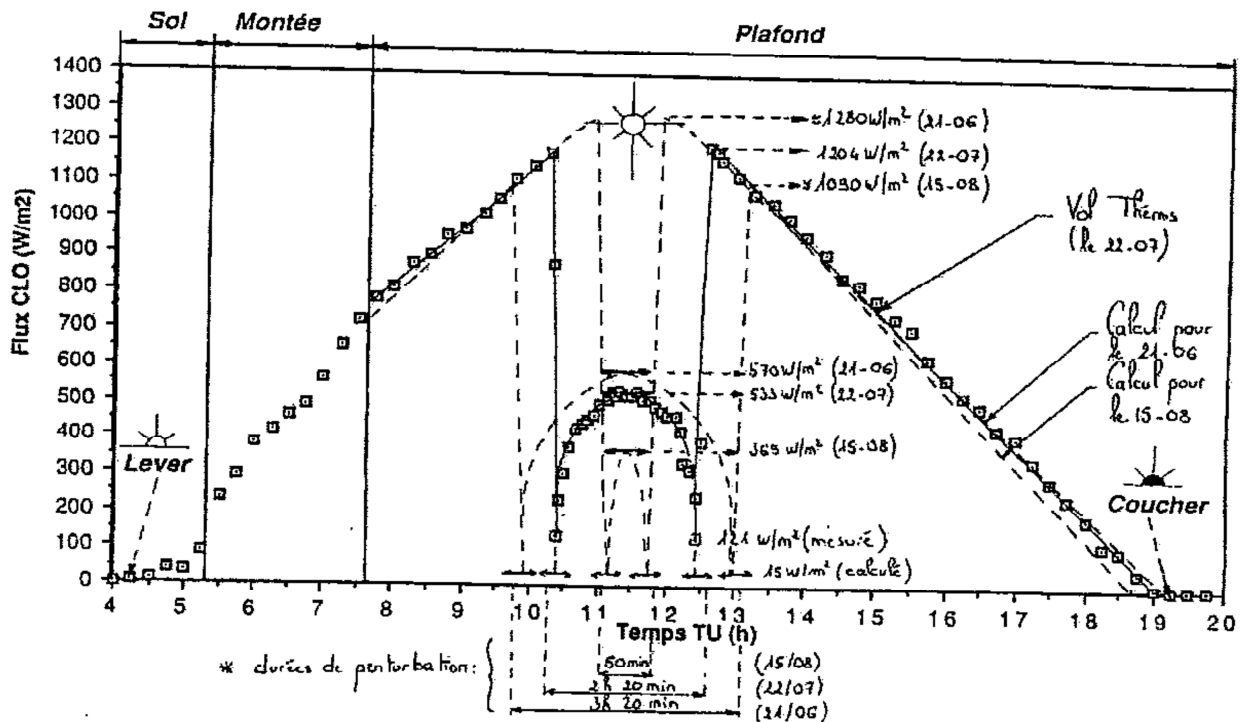

Figure 8: Effect of short-wavelength flux on the upper part of the gondola

4.2. MASKING CONE

The envelope creates a masked area for observations with a high elevation angle from the PLG. The maximum elevation before masking (α) varies within the following range:

Favourable case (max. α)

5SF: Diameter of the carrier vehicle: 18.9m ($r=9.45m$) / $h = 0.95+0.2 + \text{min L para (32m)} + 0.7+1.1+7+75+0.3+2.7 = 87.95m + \text{min L para (32m)} = 119.95m$.

Max. $\alpha = 85.49$ deg.

Unfavourable case (min. α)

1203Z: Diameter of the carrier vehicle: 148.3m ($r=74.15m$) / $h = 0.95+0.2 + \text{min L para (32m)} + 0.7+1.1+7+75+0.3+2.7 = 87.95m + \text{min L para (32m)} = 119.95m$.

Alpha min = 58.27 deg.

If the masking could compromise the scientific mission, the flight train can be lengthened to increase the maximum elevation angle before masking. Such cases will be treated after a full analysis of the technical questionnaire.

4.3. SOLAR RADIATION

4.3.1. DIRECT SOLAR FLUX

Outside the atmosphere, the direct solar flux is equal to the solar constant. In the atmosphere, the direct solar flux is attenuated as a result of diffusion and absorption by the components of the atmosphere. It then depends on the altitude and the position of the Sun in relation to the zenith (given by the solar zenith angle). Because of the scarcity of air in the upper layers of the atmosphere, during the day a ZPB at its ceiling will be subject to a density of direct solar flux close to the solar constant for a wide range of solar zenith angles.

The eccentricity of the Earth's orbit causes variations in irradiance during the year:

	Solar constant
Winter solstice	1415±W/m ²
Spring equinox	1382±W/m ²
Summer solstice	1326±W/m ²
Autumn equinox	1362±W/m ²

The solar constant has a mean annual average value of 1371W/m².

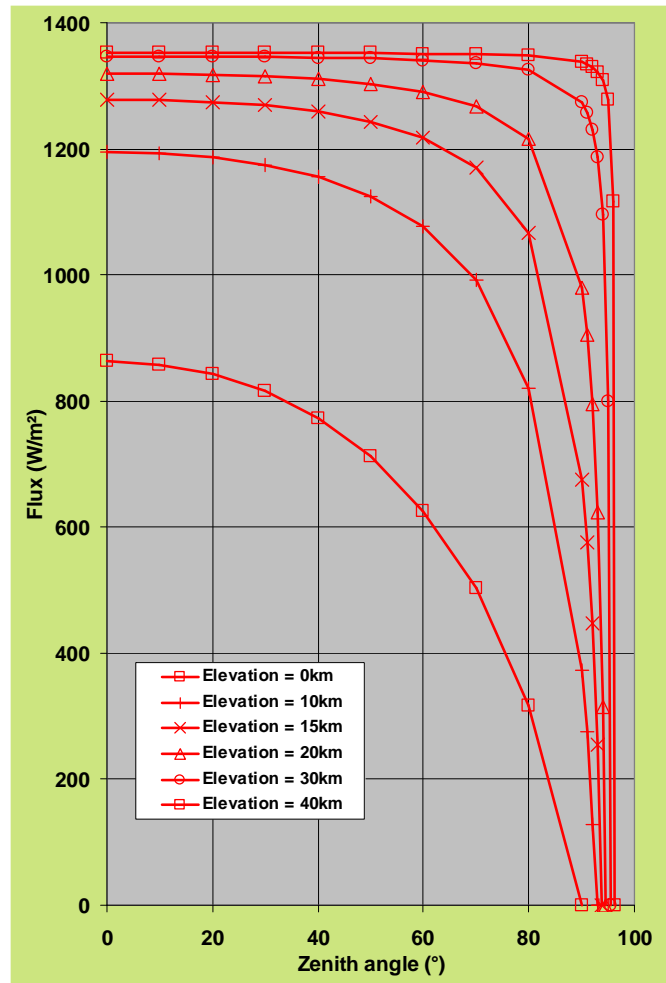

Figure 9: Solar constant, with examples of the density of direct solar flux in the atmosphere

4.3.2. ALBEDO

The albedo is the result of diffuse scattering of the direct solar flux by the ground, and of diffuse scattering and transmission of the solar flux by the clouds. It depends on the albedo coefficient (or reflection coefficient) of the area overflown (terrestrial landscape, clouds) and, like the direct solar flux, it is subject to attenuation resulting from diffusion and absorption by the components of the atmosphere.

In the stratosphere, the density of albedo flux can be quite high (in the region of 400W/m²) when flying over a landscape covered with fresh snow, for example.

Type of cloud	Albedo coefficient
Cumulonimbus	~1
Cumulus	0.56 to 0.81
Altostratus	0.39 to 0.59
Stratus 200m thick	0.1 to 0.5
<i>Mean albedo:</i>	<i>0.5</i>

Terrestrial landscape	Albedo coefficient
Fresh snow	0.8 to 0.9
Old snow	0.45 to 0.7
Desert	0.24 to 0.28
Grass	0.15 to 0.3
Dry ground	0.08 to 0.14
Moist ground	0.08 to 0.09
Forest	0.04 to 0.1
Ocean	0.03
<i>Mean albedo:</i>	<i>00:29</i>

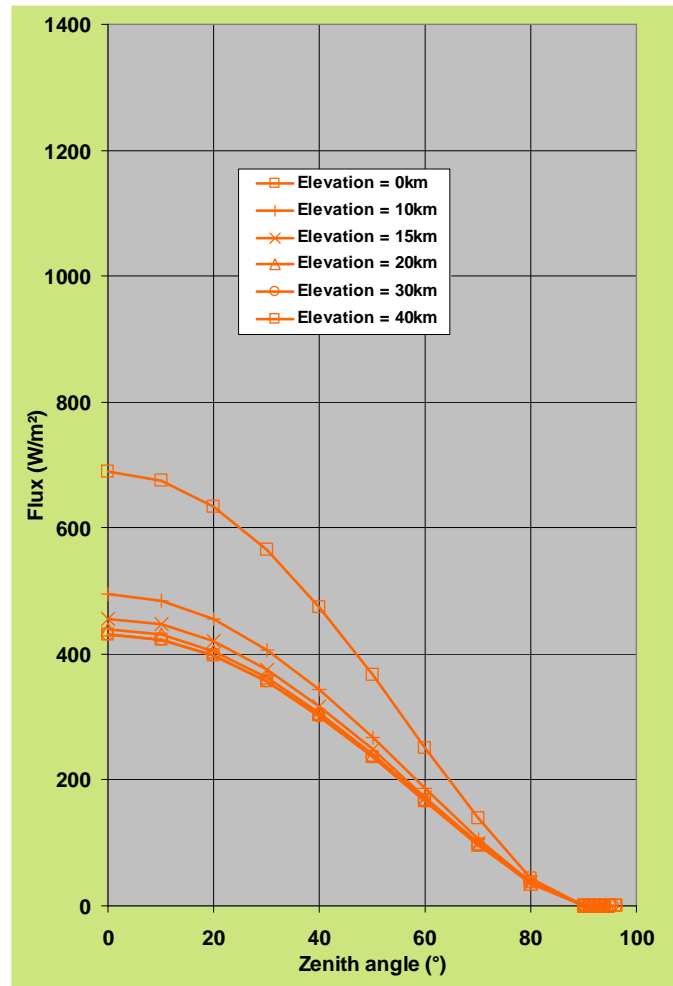

Figure 10: Examples of values for albedo coefficients and albedo flux density in clear skies for a ground albedo coefficient of 0.8 (fresh snow)

4.4. INFRARED RADIATION

The aerostat is subjected to rising infrared radiation and descending infrared radiation.

Rising infrared radiation is often called terrestrial infrared radiation as it mostly comes from the ground. The diffuse infrared radiation emitted by the Earth's surface is partially transmitted by the air and the clouds themselves emitting in the infrared waveband.

The CNES models estimate this in international standard atmosphere (ISA) at approximately 390W/m² at 1000hPa and approximately 220W/m² at 2hPa in clear skies.

Descending infrared radiation corresponds to the diffuse infrared radiation emitted and transmitted by the air and the clouds (if the aerostat is moving through the troposphere).

The CNES models estimate this in international standard atmosphere at approximately 250W/m² at 1000hPa. In clear skies this then decreases regularly to reach a few W/m² in the stratosphere as a result of the scarcity of the air in the upper atmospheric layers.

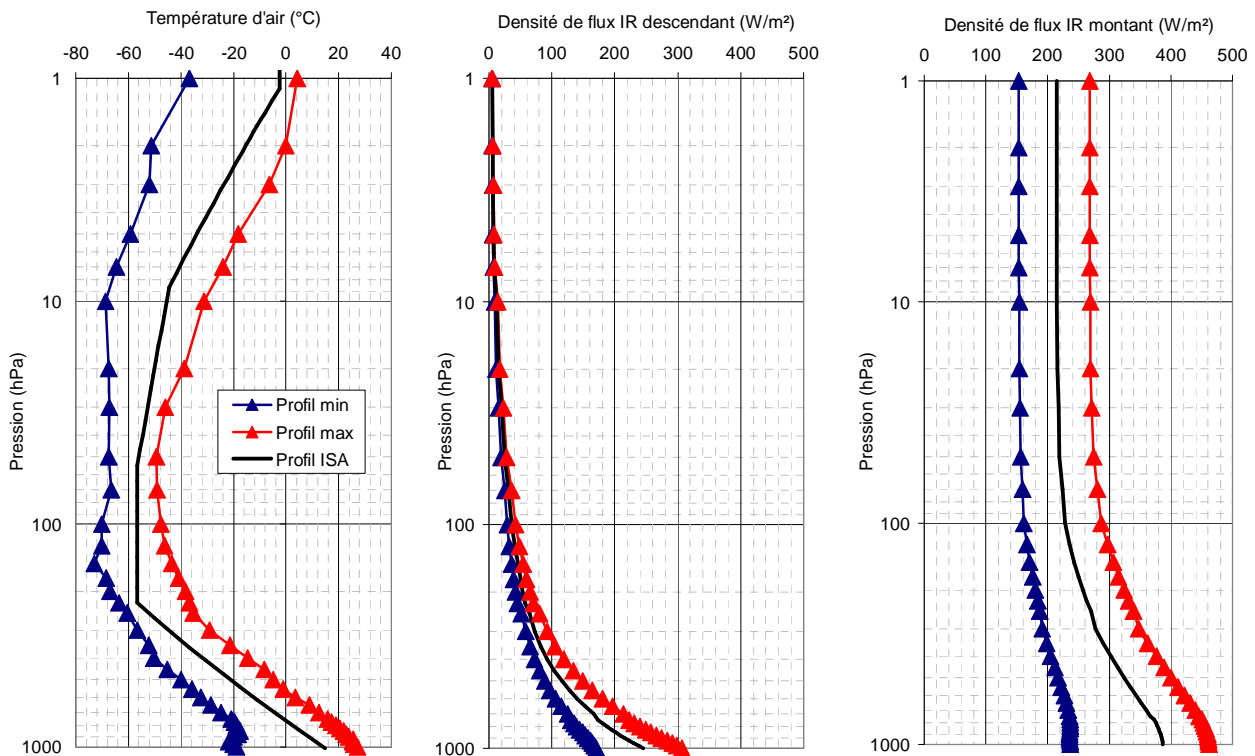

Figure 11: Densities of rising and descending infrared radiation obtained in clear skies

4.5. AIR PRESSURE AND TEMPERATURE

Atmospheric pressure decreases by a factor of 10 approximately every 16km in altitude gained (see standard atmosphere given in DR1). It is 100hPa at 16km, 25hPa at 25km, 10hPa at 31km and 2hPa at 42km. Balloon pilots habitually use pressure as a vertical coordinate.

The troposphere (the layer of atmosphere from the ground to the tropopause) includes horizontal variations of pressure, and the altitude of the isobars varies with the presence of troughs and anticyclones.

Air temperature in the troposphere decreases on average by 6.5°C per kilometre. However, this decrease may not occur in the event of temperature inversion, which occurs in winter in the interior of continents, when ground surface cools because it receives very little of energy from the Sun.

In the stratosphere (from the tropopause to approximately 50km), air temperature increases with altitude because of the absorption of solar radiation by the ozone layer.

The upper limit of the troposphere is called the tropopause. Its altitude varies depending on the geographical area (from 8 km at the poles to approximately 18 km at the equator) and the season. It also depends on the atmospheric phenomena in the troposphere.

The most "stable" temperature profile in the troposphere and stratosphere during the year is found in the equatorial zone, where there is little variation in sunshine. The air temperature profile in the tropical zone is similar to the air temperature profile in the equatorial zone.

In the temperate zone, there is considerable variability of temperatures depending on the season and also on the origin of atmospheric air masses, which alter the temperature profile according to their origin. Lastly, the poles are the areas with the greatest variations in solar radiation and therefore in temperature.

The figures below show the extremes of air temperature that can be encountered for flights

launched from the Timmins base. These temperatures are derived from the ECMWF's ERA-Interim reanalyses from 1 April to 31 October, for the years 1990 to 2010, and a horizontal resolution of 0.5° and 1°. The mean air temperature is very close to the ISA profile, while the extremes show a mean deviation of approximately 18°C (not illustrated) and can reach a minimum temperature of approximately -40°C at 2hPa.

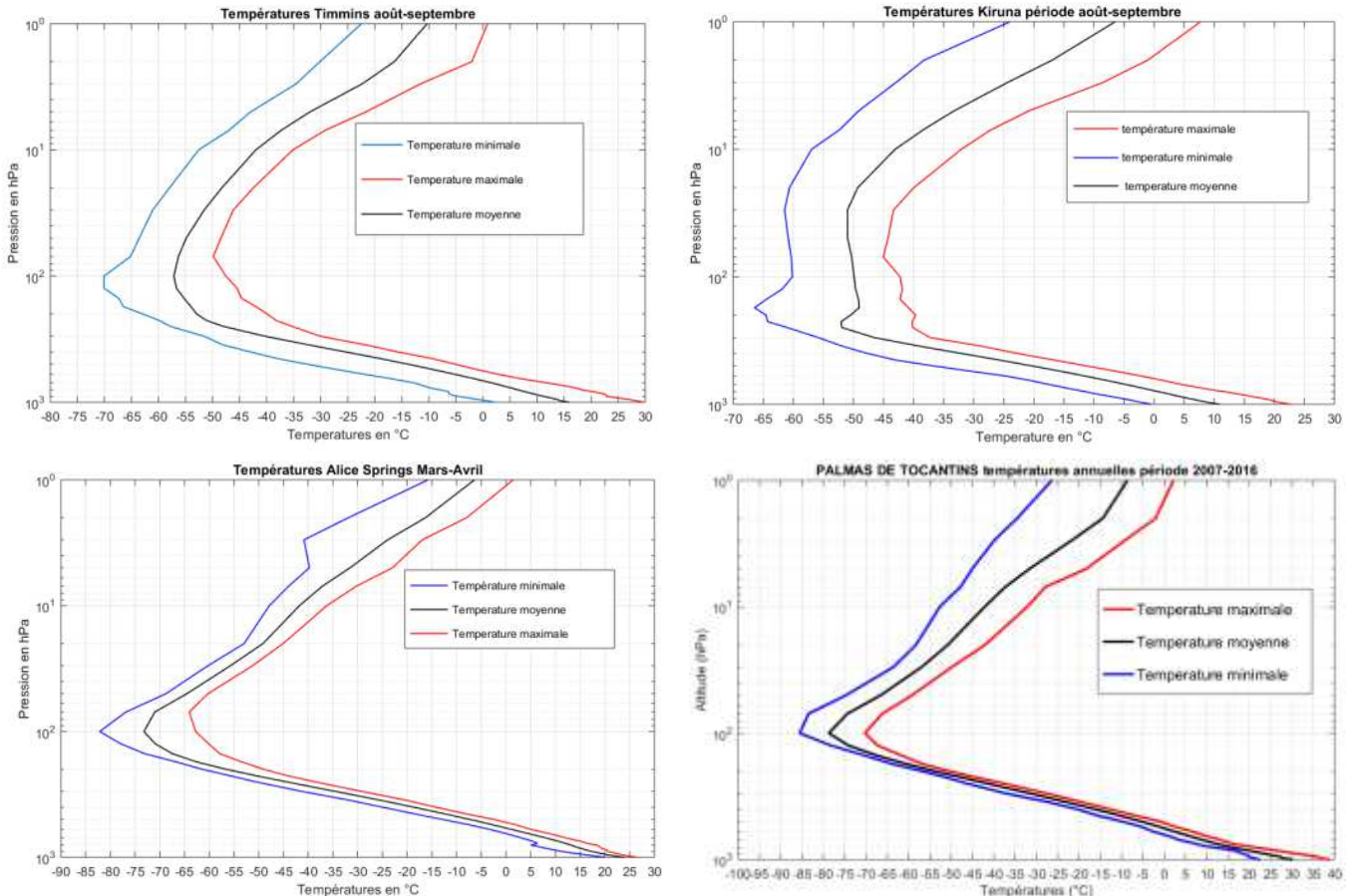

Figure 12: Air temperatures derived from the ECMWF's ERA-Interim reanalyses

4.6. RADIATION

Concerning radiation, the protection of the aerostat system's flight control equipment has been sized on the basis of the following results from balloon flights made during previous campaigns. These data can serve as a reference for assessing the protection to be provided for the most vulnerable instruments, and depending on the time they will remain exposed.

Extract from the report of the ONERA study "Impact de l'Environnement Radiatif Naturel Atmosphérique sur les nacelles électriques embarquées sur ballons" (Impact of the Natural Atmospheric Radiation Environment on the electrical gondolas carried by balloons) written by G. Hubert and referenced as RF 1/20635 DESP – November 2012.

"The flux of neutrons in the atmosphere varies with altitude and latitude. In Figure 3-a, showing the variation of the neutron flux as a function of altitude for a latitude of 43°N, we note that the flux increases with the altitude, reaching a maximum at 18 km (~1.25 n.cm⁻².s⁻¹), known as the Pfozter maximum, and declining thereafter. This evolution is the result of the interaction between the cosmic particles, whose flux increases with altitude, and the atmosphere, whose density decreases with altitude (given by the US Standard Atmosphere, 1962).

Figure 3-b shows the flux of neutrons in the atmosphere for a range of energies from 1 to 10 MeV as a function of latitude and for an altitude of 10.7 km. We note that this flux is very low at the equator ($\sim 0.2 \text{ n.cm}^{-2}.\text{s}^{-1}$) and reaches a maximum value ($\sim 1.4 \text{ n.cm}^{-2}.\text{s}^{-1}$) at the Poles. We find the same behaviour regarding latitude as that of cosmic rays arriving in the atmosphere (minimum flux in equatorial regions and maximum in polar regions). Since the production of neutrons in the atmosphere is directly linked to incident cosmic particles, neutron flux is also dependent on latitude.

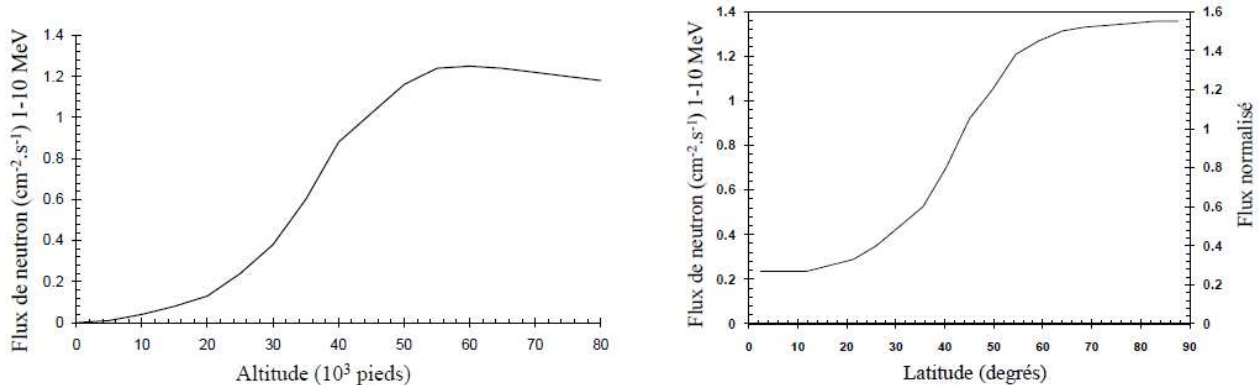

Figure 3-a Flux de neutrons dans l'atmosphère ($1 < E < 10 \text{ MeV}$) en fonction de l'altitude. On remarque un flux maximum de $\approx 1,25 \text{ n/cm}^2.\text{s}$ pour une altitude de $\approx 60000 \text{ pieds}$ ($\approx 18 \text{ km}$). Figure 3-b. Flux de neutrons dans l'atmosphère ($1 < E < 10 \text{ MeV}$) en fonction de la latitude pour une altitude $\approx 10,7 \text{ km}$. On remarque un flux quasiment nul ($\approx 0,2 \text{ n.cm}^{-2}.\text{s}^{-1}$) au niveau de l'équateur (champ magnétique terrestre fort) et un flux maximum ($1,4 \text{ n.cm}^{-2}.\text{s}^{-1}$) au niveau des pôles (champ magnétique terrestre faible).

It is quite common practice to consider only neutrons and to ignore other types of particles. However, we must not neglect the proton component, which can also be a cause of Single Event Effects. This is particularly true for balloon applications. Up to altitudes of about 18-20 km, it is justifiable to consider only neutrons; however, at high altitudes (typically higher than 25 km), protons can become the majority component (this depends on the latitude in question). For example, at an altitude of 40 km, neutrons can be ignored, while the protons are in the majority. Moreover, when studying high energies ($>$ about 100 MeV), the proton component is the most important.

In other words, for balloon applications, characterisation of the atmosphere's natural radiative environment requires that we consider both neutrons and protons. Regarding the effects, it is widely accepted that the induced effects are equivalent for energies of about 50 MeV and above."

Here is another reference concerning the assessment of levels of radiation in the stratosphere:

RADIATION MEASUREMENTS IN THE STRATOSPHERE

Denis Pantel, Yago Gonzalez, Mickael Gedion, Frédéric Wrobel, Jean-Roch Vaillé, Frédéric Saigné

Université Montpellier 2, UMR-5214, CC083, Place Eugène Bataillon, 34095 Montpellier CEDEX 5

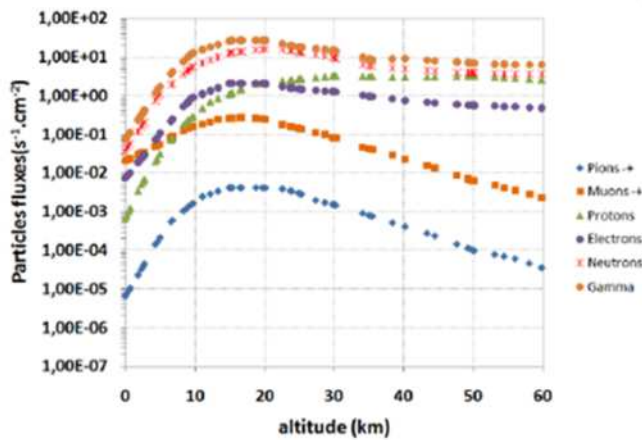

Figure 1 : Particles fluxes as a function of altitude [7].

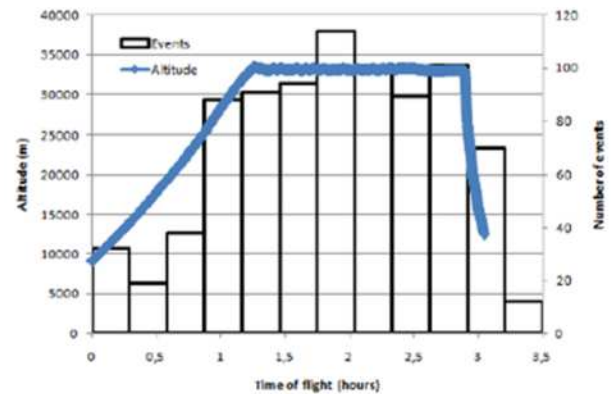

Figure 9 : Comparison between the evolution of the number of detected events as a function of time of flight and altitude profile.

4.7. SHEDDING BALLAST

To control the balloon's altitude, ballast can be released during different phases of the flight. This means dropping metal beads made of a stainless-steel alloy, with a diameter of less than 2 mm and a mass of 0.02 grams, from the NSO, located approximately 70 meters above the PLG, which can thus be affected.

These operations are commanded by radio after coordination between the Operations Manager and the PI. If equipment on the PLG needs to be protected, CNES will help install protection over the PLG.

5. CERTIFICATION REQUIREMENTS

CNES is responsible for certifying the PLG and specific instruments. The certification analysis is carried out on the basis of the information provided by the PI for the purpose of demonstrating compliance with the requirements listed below.

Compliance with the requirements must be demonstrated before the campaign and may require technical discussions between CNES and the PI.

All the requirements listed below concern PLGs developed by a scientific laboratory or manufacturer. Among these, those applicable to instruments taken into account on CNES gondolas are identified by an asterisk (*).

On site, the Launch Manager verifies that the PLG (and its integrated elements) are fully compliant before the flight, particularly for the mechanical aspects. **The PI is responsible for informing the Mission Manager of any deviation from the certification file.**

5.1. MECHANICAL SPECIFICATIONS

The principles behind the design, development and implementation applicable to payload gondolas must include mitigation of the risks specific to their preparation, flight and recovery, including:

- unhooking and falling of the PLG.
- detaching, tearing away or unexpected leakage of a component of the PLG.

5.1.1. INTERFACES BETWEEN THE PLG AND THE ZPB SYSTEM

This section describes the interfaces between CNES equipment and scientific equipment and defines the design specifications for the latter.

Its content serves as a basis for designing the mechanical interface between the PLG and the CNES flight train; CNES supplies nothing beyond the attachment link(s): 2 x MRDI \varnothing 12 or 1 x MRNI \varnothing 14.

5.1.1.1. Mechanical Interface between flight train and the PLG

The main PLG is located at the lowest point of the aerostat, under the mechanical separator of the auxiliary balloon.

A secondary PLG may be attached to the main PLG at 4 points. This configuration needs to be dealt with on a case-by-case basis with CNES.

The mechanical interface between the PLG and the aerostat can be made in two different ways, as:

- a double mechanical interface, or,
- a single mechanical interface.

EX-0-MNU-00010

The design of the PLG must take these data into account for the mechanical interface with the flight train.

The upper and lower interfaces of the quadruple point (PQUA) are spaced 240 mm apart (from neutral fibre to neutral fibre). The geometrical characteristics of the PQUA are given in the following figure:

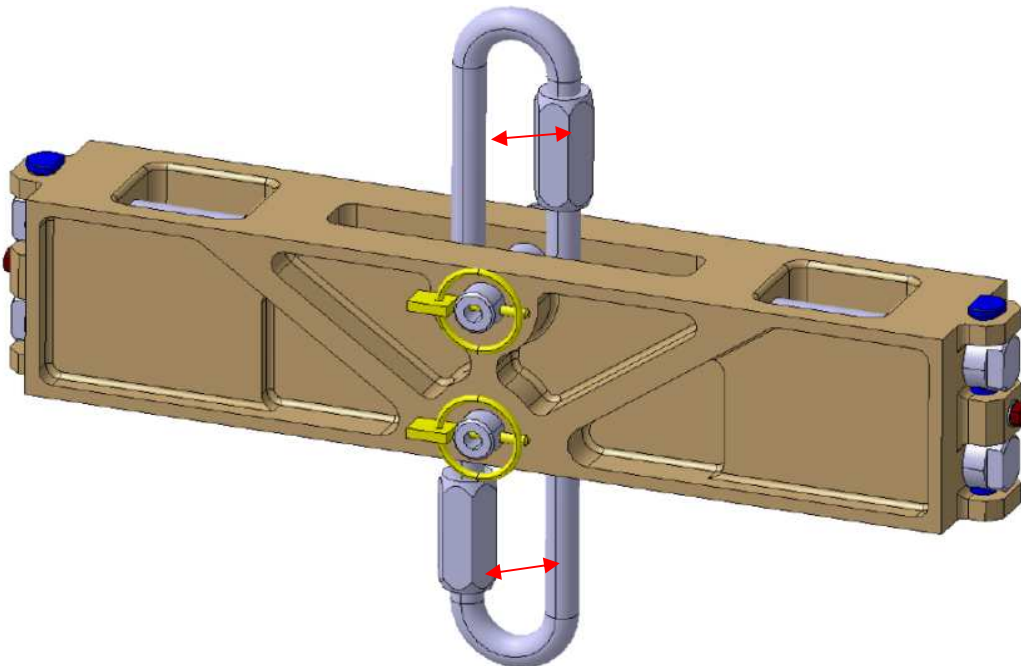

Figure 13: Clearance of the upper and lower interfaces of the PQUA

Double interface

In the case of a double interface, the mechanical interface between the PLG and the aerostat consists of two straps 2700 mm long connecting the PLG to the lower interface of the PQUA. Two MRDI12 quick links are used to interface between the PLG and the straps.

The distance between the two MRDI \varnothing 12 links interfacing with the PLG must be between 300 mm and 60 mm. The following figures illustrate the possible configurations:

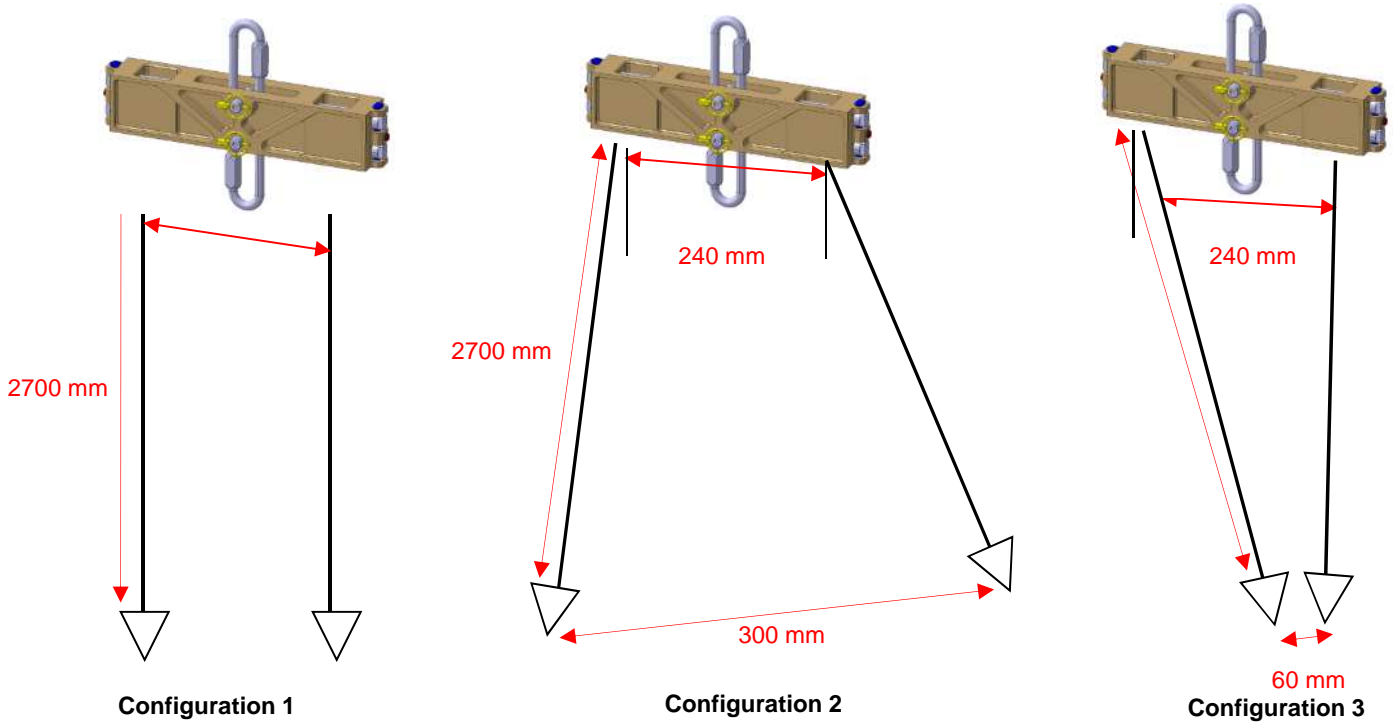

Figure 14: Configurations with double interface

The two MRDI12 links interfacing with the PLG must be positioned in the same plane (correct interfacing) and not on two separate parallel planes (incorrect interfacing).

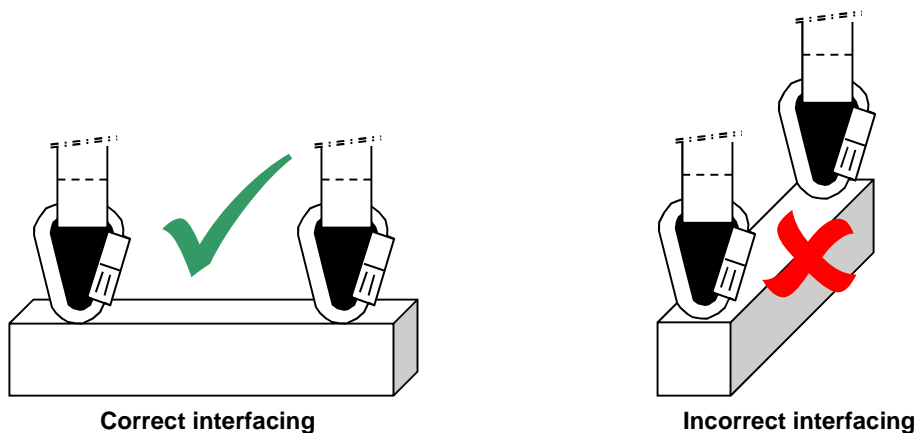
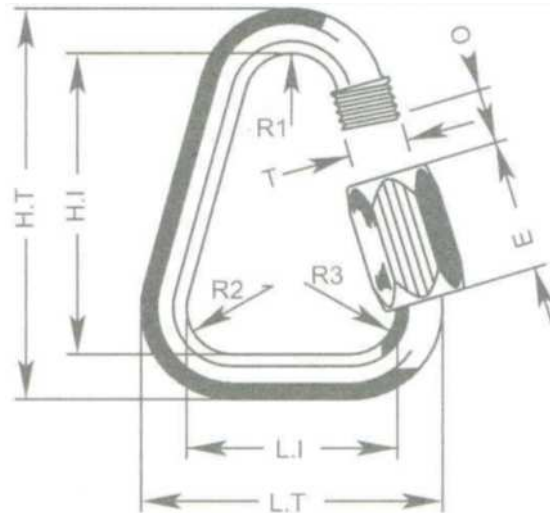

Figure 15: Positioning of the MRDI \varnothing 12 links interfacing with the PLG

The following figure and table give the characteristics of the MRDI \varnothing 12 links:



Ref.	Diameter		Dimensions (in mm)							
	mm	inches	L.T.	L.I.	H.T.	H.I.	O	E	R1-2-3	T
MRDI \varnothing 12.0	12	1/2"	75	51	104	80	15	33	11.75	15

Figure 16: The dimensional characteristics of an MRDI \varnothing 12 link

Single interface

In the case of a double interface, the mechanical interface between the PLG and the aerostat consists of two straps 2700 mm long connecting the PLG to the lower interface of the PQUA. The interface with the PLG is a single MRNI \varnothing 14 link which uses two MRDI \varnothing 12 links to interface with the straps. The following figure illustrates this configuration:

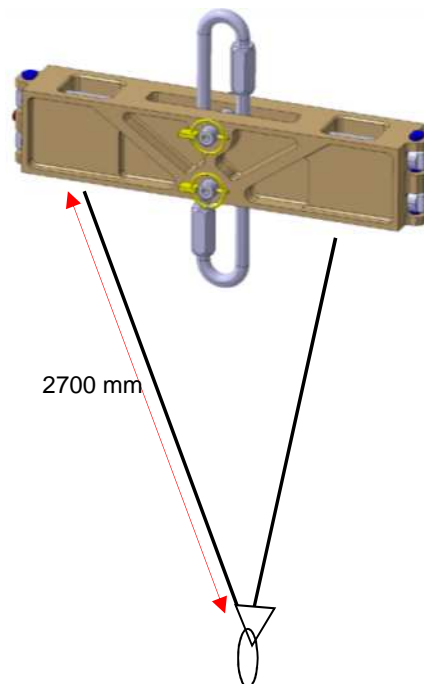
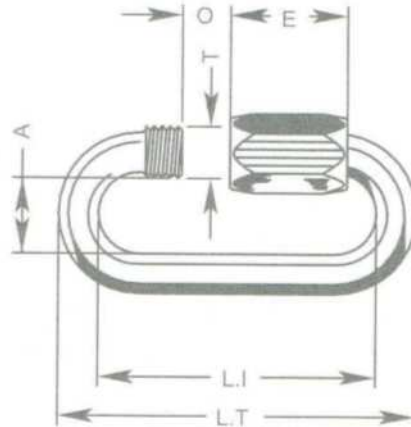

Figure 17: Configuration of the single interface, with an MRNI \varnothing 14 link interfacing with the PLG

The following figure and the table give the characteristics of the MRNI \varnothing 14 links:



Ref.	Diameter		Dimensions (in mm)					
	mm	inches	L.T.	L.I	A	O	E	T
MRNI \varnothing 14.0	14	9/16"	121	93	27	17	39	17

Figure 18: The dimensional characteristics of an MRNI14 link

5.1.1.2. Mass

The maximum stabilised altitude the aerostat can reach is a function of the mass of the PLG (or the sum of the masses of the PLGs). This is illustrated in the following figure (for a standard atmosphere).

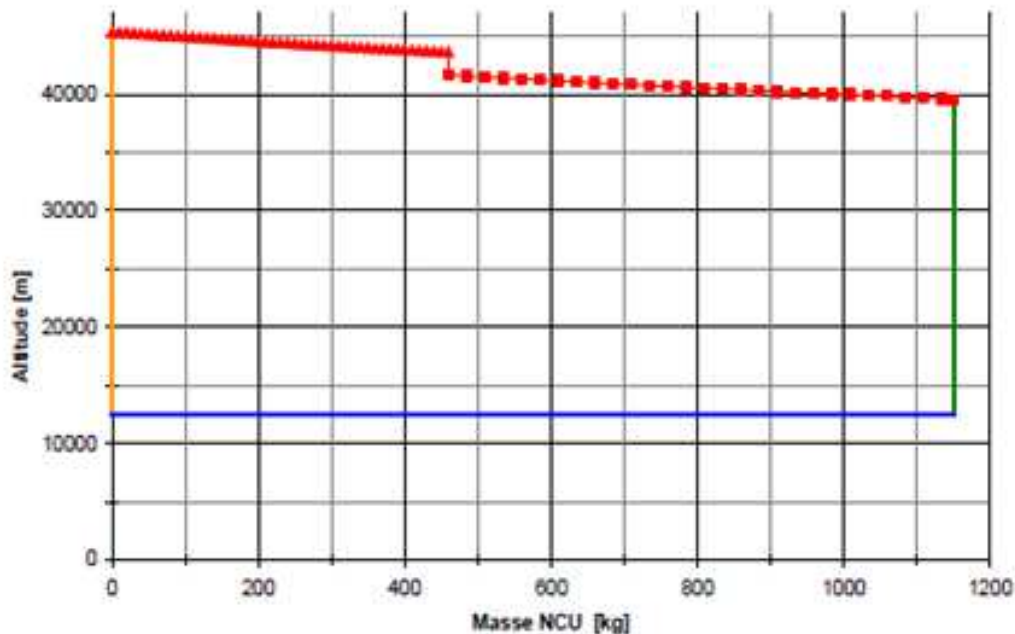

The lower altitude limit (blue line) is given by the minimum altitude for destruction of the envelope (180hPa, in other words 12,452m ISA).

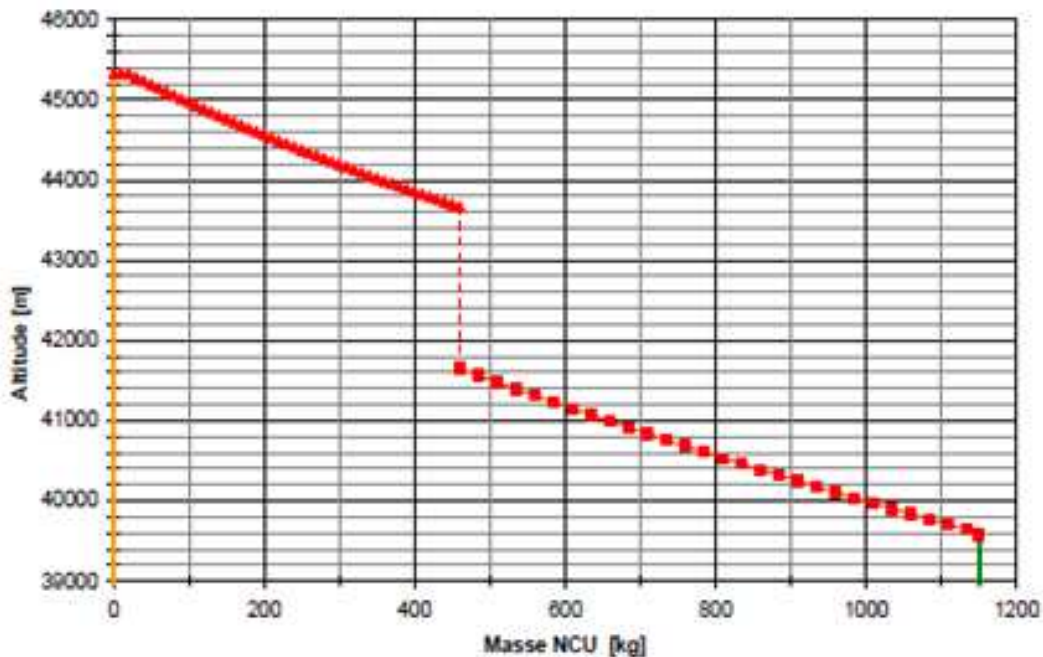

The upper altitude limit (red line) is given by the maximum flight altitude of the envelopes 1202Z and 803Z, taking a combined mass of 575 kg for housekeeping systems and ballast into account. The part of the red curve indicated with triangles is the limit for envelope 1203Z, the part of the red curve indicated with squares is the limit for envelope 803Z.

Figure 19: Maximum altitude as a function of the weight of the PLG in a standard atmosphere

EX-0-MNU-00100

The mass of the PLG (or the sum of the masses of the PLGs) must be greater than 120 kg and less than 1100 kg.

5.1.1.3. Volume in flight configuration

EX-0-MNU-00200

The maximum surface area taken up on the ground is 5 m x 5 m.

Kiruna base (Sweden):

- Basilic building
 - o maximum clearance under mobile hoist: 7.0 m (maximum load 3200 kg);
 - o dimensions of the doorway: 6.95 m x 4.75 m (h x l).
- Dome building
 - o maximum clearance under mobile hoist: 7.0 m (maximum load 4,000 kg);
 - o maximum clearance under fixed hoists (x4): 7.0 m (maximum load 400 kg);
 - o dimensions of the doorway: 10.0 m x 7.0 m (h x l).

Timmins base (Canada):

- o maximum clearance under mobile hoist: 7.5 m (maximum load 1500 kg);
- o maximum clearance under fixed hoists (x2): 6.0 m (maximum load 1000 kg);
- o dimensions of the doorway: 5.0 m x 4.0 m (h x l).

A specific request should be submitted for any gondola exceeding the allocated volume.

5.1.1.4. Load balancing

EX-0-MNU-00300

The centre of gravity must be positioned so that the forces on the straps are distributed correctly and the effects of pitch and swaying minimised. The maximum difference must be less than 20% if the attachment consists of two slings.

Recommendation:

a study will be made to ensure that the gondola's centre of gravity and inertia ensure good stability at the moment the parachutes open and avoid any significant rotation that could cause strong additional loads.

5.1.1.5. Pivoting systems and pointed gondolas

EX-0-MNU-00400

Some gondolas are equipped with a pivot system. As this is part of the gondola, the same sizing margins must be applied. For safety purposes:

- a "balcony" will be installed to limit the vertical pivoting angle when re-tensioning occurs as the parachute opens during separation;
- to provide a safe environment for the axis of the gimbal, cables on the lower part of the pivoting system or a cage enclosing the pivoting system will be used.

5.1.2. MECHANICAL STRESS

5.1.2.1. Design of mechanical elements

The mechanical design of the PLG must comply with the following principles:

- the Limit Load (LL) multiplied by the different safety factors taken into consideration during the sizing process must remain lower than the elastic limit of the material – Yield Load (YL);
- LL multiplied by the different safety factors taken into consideration during the sizing process must remain below the ultimate strength of the material – Ultimate Load (UL).

The Limit Load is defined on the basis of specified loading cases (see requirements EX-0-MNU-00700 and EX-0-MNU-00800).

The different safety factors to be taken into account are:

- a project coefficient (KP);
- a model coefficient (KM);
- a safety coefficient based on the Yield Load (FOSY: Factor Of Safety Yield);
- A safety factor based on the Ultimate Load (FOSU: Factor of Safety Ultimate).

By definition:

- DLL (Design Limit Load) = $LL * KP * KM$;
- DYL (Design Yield Load) = $DLL * FOSY$;
- DUL (Design Ultimate Load) = $DLL * FOSU$.

The safety margins are calculated as follows:

- MOSY (Margin Of Safety Yield) = $(YL/DYL) - 1$;
- MOSU (Margin Of Safety Ultimate) = $(UL/DUL) - 1$.

EX-0-MNU-00500

For each loading case considered, a synthetic reference table will give the MOSY and MOSU margins for each of the structural elements to be scaled.

EX-0-MNU-00510

The MOSY and MOSU safety margins must be positive, when using the following minimum coefficients:

- FOSY = 1.25
- FOSU = 1.5

EX-0-MNU-00520

For any materials whose mechanical characteristics are unknown regarding the entire range of environmental conditions they may meet, the FOSY and FOSU safety coefficients must be submitted to CNES for approval.

EX-0-MNU-00530

For fragile materials (ceramics, glass, etc.), the FOSU safety coefficient must be submitted to CNES for approval.

EX-0-MNU-00540

The default value for the model coefficient (KM) is 1.4. Nevertheless, the project group in charge of the justification of the mechanical design of the gondola considered may propose the use of a lower KM coefficient, as long as $KM \geq 1.2$. The project group must justify its choice, which will be submitted to CNES for approval.

EX-0-MNU-00550

CNES recommends a project coefficient (KP) = 1.15. This coefficient should enable scientists to upgrade their instruments over time without systematically needing to modify the structure. Nevertheless, the project group in charge of justifying the mechanical design may propose the use of a lower KM coefficient, as long as $KM \geq 1$. CNES will not accept a justification with $KP < 1$.

EX-0-MNU-00560

The differential expansion of different materials that interface with one another can cause additional mechanical stresses. During the design phase of structural elements, particular attention must be paid to the fitting and/or the mechanical sizing of this type of interface.

5.1.2.2. Assembly with with nuts and bolts**EX-0-MNU-00600***

In order to be able to monitor the behaviour of nut-&-bolt mountings, either a torque mark will be affixed, or a device to prevent loosening will be used (spring lock washers, torque wrench with flat washers, threadlock, etc.).

5.1.2.3. Accelerations

The most extreme acceleration occurs during the separation and the opening of the parachutes. The PLG is then subjected to a strain that is a function of its mass, the mass of the NSO and the rigidity of the links between these gondolas.

EX-0-MNU-00700*

The PLG and its elements must withstand the combined stresses resulting from the sizing cases listed below, without becoming unhooked or detached.

PLG mass	Maximum vertical acceleration (Z axis) on the PLG	Horizontal acceleration on the PLG
100	12.4 g	2.5 g
200	8.3 g	1.7 g
300	7.9 g	1.6 g
400	7.6 g	1.5 g
500	7.2 g	1.4 g
600	6.8 g	1.4 g
700	6.4 g	1.3 g
800	6.0 g	1.2 g
900	5.6 g	1.1 g
1000	5.3 g	1.1 g
1100	5.0 g	1.0 g
1200	4.8 g	1.0 g

Recommendation: since it is not possible to specify the environment on landing, the following recommendations should be taken into account:

- design ultimate load for a 15 g shock in the vertical plane;
- design the interfaces of gondola equipment for an ultimate load equivalent to a 5 g shock in the horizontal plane.

5.1.2.4. Vibration

During the recovery phase, transport back to the launch base can generate vibration stresses at a level equivalent to 3.85 g rms, which corresponds to the acceleration spectral density below.

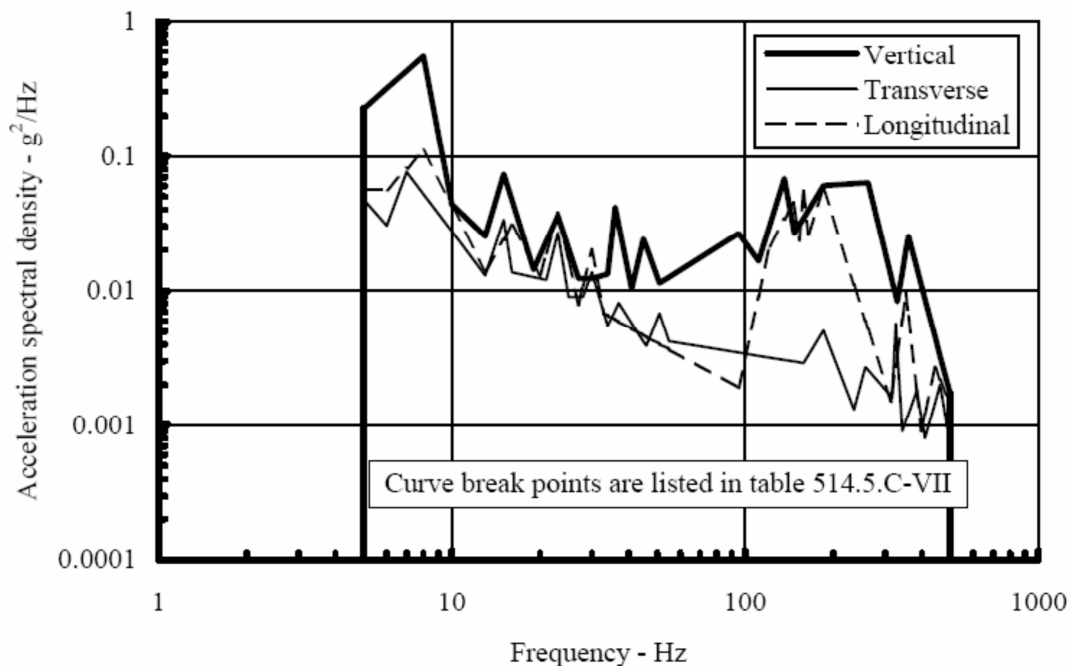

Figure 20: Acceleration spectral density of vibration loads

EX-0-MNU-00800*

During the recovery phase, during transport back to the base, the PLG and its elements must withstand, without detaching, vibration loads at a level equivalent to 3.85 g rms, which corresponds to the acceleration spectral density above. This may be demonstrated by tests or calculations.

5.1.2.5. Dynamic pressure

During the return to ground phase, the PLG is likely to undergo rapid variations in pressure ranging from 3 hPa to ambient pressure on the ground, at a maximum rate of 1 hPa/s.

EX-0-MNU-00900*

The PLG must be able to withstand rapid variations in pressure ranging from 3 to 1000 hPa at a maximum rate of 1 hPa/s

5.1.2.6. Impact indicators

It is recommended to equip the gondolas, from their very first flight, with two shock indicators, also known as impact indicators. These two indicators must be as far as possible away from each other. The recommended impact indicators are G-Print or Recorda-g which record shocks of up to 170 g for a minimum time of 7 ms (140 Hz) and operate without any degradation between -30°C and +120° C. The films to be used must be annotated (gondola, date, place, flight, campaign, etc.) and kept with the gondola's logbook. Other types of indicators can be used, such as OMNI-G ball-bearing indicators, or MAG 2000 devices.



Figure 21: Examples of impact indicators RECORDA-G, OMNI-G and MAG 2000

EX-0-MNU-01000

The PLG will be equipped with a shock-absorption device compatible with a maximum vertical velocity at landing of 7 m/s.

This speed is not a safety limitation, but the maximum speed of arrival on the ground for which the energy absorption systems of current PLGs are designed. For each PLG, the choice of parachutes

is based on an average landing speed of 6 m/s.

CNES can provide cardboard shock-absorbers.

EX-0-MNU-01010

If specific mechanical shock-absorbers are necessary, then the scientific teams will be responsible for developing them.

EX-0-MNU-01020

The prime contractor for the gondola will also equip the PLG with an accelerometer to measure the real impact on landing.

5.1.2.7. Particular case of composite materials

Concerning the use of composite materials, the following precautions should be taken. The designer of the gondola should validate the process for obtaining the composite parts by carrying out mechanical characterisation tests on samples after degassing at a pressure of 1 hPa and a temperature of 40°C (TBC).

EX-0-MNU-01100

Composite parts must be designed on the basis of these characterisations, taking the following additional margins into account: KM coefficient ≥ 1.6 .

5.1.3. TEMPERATURES

EX-0-MNU-01200*

Experiment managers shall undertake to package their experiments in such a way as to eliminate any risk of deterioration of their equipment during the different phases of the flight and to enable the equipment to withstand the stresses due to the launch and recovery operations. And in particular:

- thermal protection of equipment carried on board for temperatures ranging between - 80°C and + 50° C.
- protection against rain and frost (in particular for optical devices).

EX-0-MNU-01210*

It must be possible to store the various components of the PLG identified as critical (at least the structure) at temperatures that can range from -40°C to +50°C (transport, release site, recovery zone, etc.).

5.1.4. TRANSPORT

The PI shall pay for transporting the PLG and any instruments.

However, CNES may pay for shipping under standard conditions (road or sea) between Aire-sur-l'Adour and the launch site (loading in a 20-foot container). The PI remains responsible for the cost of all other transport (shipping equipment between the laboratory or company and Aire-sur-l'Adour).

EX-0-MNU-01300*

In cases where CNES takes responsibility for transporting the PLG or an instrument, if specific precautions are to be taken, the PI will be required to provide the appropriate regulatory packaging.

5.2. ELECTRICAL AND RADIOELECTRIC RISKS

The principles behind the design, development and implementation applicable to payload gondolas must include mitigation of the risks specific to their preparation, flight and recovery, including:

- risk of fire endangering the integrity of the system, of people or goods, on the ground or in flight;
- risk of electric shocks;
- risk of breakdown;
- risk of interference with other PLGs or balloon systems (compliance with the frequency plan).

EX-0-MNU-20000*

There is no electrical interface between the PLG and the other elements of the flight train, so the equipment making up the PLG must be self-sufficient in terms of energy supply.

5.2.1. RISK OF FIRE

EX-0-MNU-20010*

In order to avoid a fire that could spread to the rest of the balloon, the gondola and/or each instrument shall be equipped with a system (such as a fuse) to prevent overloading of the circuits. Similarly, all cables should be rated for a current equal to or greater than that tolerated by the circuit breaker.

EX-0-MNU-20020*

Equipment requiring ventilation or with an integrated ventilation system must be installed according to the manufacturer's instructions. In particular, the minimum distances between devices must be kept.

5.2.2. RISK OF ELECTRIC SHOCKS

EX-0-MNU-20100*

To protect the personnel handling the gondola from electric shocks and to avoid the accumulation of static electricity in the latter, it is necessary to ensure that static charges are drained away.

EX-0-MNU-20110*

The system installed to drain static charges must remain constantly functional while work is being performed on the gondola (such as installation, attachment and recovery). This can be a grounding lead on the outside of the gondola.

EX-0-MNU-20120*

All cables must be insulated, protected and secured.

5.2.3. RISK OF BREAKDOWN

EX-0-MNU-20200*

The Experiment Manager undertakes to provide sufficient autonomy for the different circuits of the experiment (to cover prolonged countdown or extended flight time).

EX-0-MNU-20210*

However, in the event of a power failure, there must be no change in the state of any safety barrier and the systems at risk must switch to safe mode.

EX-0-MNU-20220*

The alarm and safety systems must be designed such that any failure is signalled.

5.2.4. SYSTEMS SUBJECT TO RISK

EX-0-MNU-20300*

The connectors of electrical circuits at risk must be designed in such a way that there is no ambiguity in their connection (mechanical guides, foolproofing devices, etc.). They must also be protected against any deterioration, and include a system for locking the connections in position.

EX-0-MNU-20310*

It must not be possible for an electrical circuit involving a risk to be activated as a result of an action on any other circuit, or through the effect of external events (static electricity, radiated fields, failure of another circuit, remote commands intended for another circuit, etc.).

EX-0-MNU-20320*

Electrical circuits involving a risk must not be routed via the same harness or pass through the same feed-throughs as those used for other circuits; they should be kept separate as far as possible. They must have specific connectors and sockets that must under no circumstances be shared with other circuits

EX-0-MNU-20330*

Electrical equipment operating in a potentially explosive atmosphere must be protected by one of the protection modes laid down in the most stringent regulations.

5.2.5. LABELLING

EX-0-MNU-20400*

Any electrical hazard must be clearly indicated on the equipment at risk, as well as on the outside of the gondola by labelling stipulated under the most stringent regulations.

5.2.6. FREQUENCY PLAN

5.2.6.1. Compatibility

In all circumstances, all participants must do their utmost to comply with the International Radio Regulations as well as the frequencies reserved for CNES for operational campaigns.

EX-0-MNU-20500*

The PLG's frequency plan listing all the frequencies of the electromagnetic emissions used by the PLG must be submitted to CNES before the campaign to check its compatibility with the campaign's frequency plan.

EX-0-MNU-20510*

The system design must guarantee that the various on-board RF links (PLG and flight control) do not cause any malfunction of the critical elements of the PLG.

EX-0-MNU-20520*

The PLG must not emit in the following wavebands:
Argos, Transponder (RX/TX), INMARSAT, GPS, IRIDIUM and WiFi.

EX-0-MNU-20530*

Irrespective of the altitude, the system must comply with the maximum levels of electromagnetic flux in all frequency bands, as defined in the International Radio Regulations.

The frequency ranges used by the flight control system are given in the following section.

5.2.6.2. List of flight control frequencies

User	Frequency band	Flight	Ground
ARGOS	401.5 to 401.7 MHz	X	
Transponder (Rx)	1030 MHz	X	
Transponder (Tx)	1090 MHz	X	
GPS L2	1227.60 MHz	X	X
GPS L1	1575.42 MHz	X	X
Globalstar	1,610 to 1,625 MHz	X	
IRIDIUM (TM/TC)	1616 to 1626.5 MHz	X	X
Broadband link (TC)	2024.85 to 2110.15 MHz	X	X
Broadband link (TM)	2199.5 to 2290.5 MHz	X	X
WiFi 802.11a	5150 to 5350 MHz	X	X
WiFi 802.11a	5470 to 5875 MHz	X	X

5.3. OTHER RISKS

5.3.1. LIST OF ITEMS AT RISK

The following systems, elements of systems, or effects of the systems can be classified items at risk:

- fluid and thermodynamic systems,
- pyrotechnic systems,
- ionising radiation,
- radioactive substances,
- non-ionising radiation,
- chemical and biological substances,
- high or low temperatures (cryogenics, etc.),
- noise (frequency and intensity),
- jettisoning parts of the PLG,
- other sources of risk / environmental pollution.

EX-0-MNU-30000*

Systems at risk must comply with the most stringent applicable regulations and their compliance must be proven by the submission of a dossier approved by a recognised inspection body.

The applicable rules specific to CNES will be notified if needed.

EX-0-MNU-30010*

Systems at risk must include:

- at least two barriers, excluding the control system, on electric circuits that could cause the loss of human lives if opened,
- at least one barrier on circuits that could cause serious injury or considerable damage if opened.

EX-0-MNU-30020*

If it is not possible to comply with the rule concerning the number of barriers, the designer of the PLG must provide workarounds (applicable during operation, via the design principles, etc.) to ensure that in the case of a simple breakdown there will be no risk of loss of life.

If the rules relating to the numbers of barriers outlined above are not met, the CNES reserves the right not to fly the gondola concerned.

EX-0-MNU-30030*

If (non-lethal) parts of the PLG are to be jettisoned without safety constraints concerning the landing area, the flight train comprising the elements dropped must comply with the requirements listed in Appendix 4 of the Standardised European Rules of the Air (SERA) for light balloons.

EX-0-MNU-30040*

If (potentially lethal) parts of the PLG are to be jettisoned with safety constraints concerning the landing area, the flight train comprising the elements dropped must comply with the requirements listed in Appendix 4 of the Standardised European Rules of the Air for heavy balloons.

CNES must be informed of the characteristics of any source of risk before it is brought onto the campaign site or before CNES takes responsibility for any PLG or instrument.

5.3.2. LABELLING

EX-0-MNU-30100*

The use of any system involving a risk must be clearly indicated on the equipment concerned, as well as on the outside of the gondola, by labelling stipulated under the most stringent regulations.

The following pictograms, used by the CNES, are taken from the AFNOR NF X 08-003 standard:

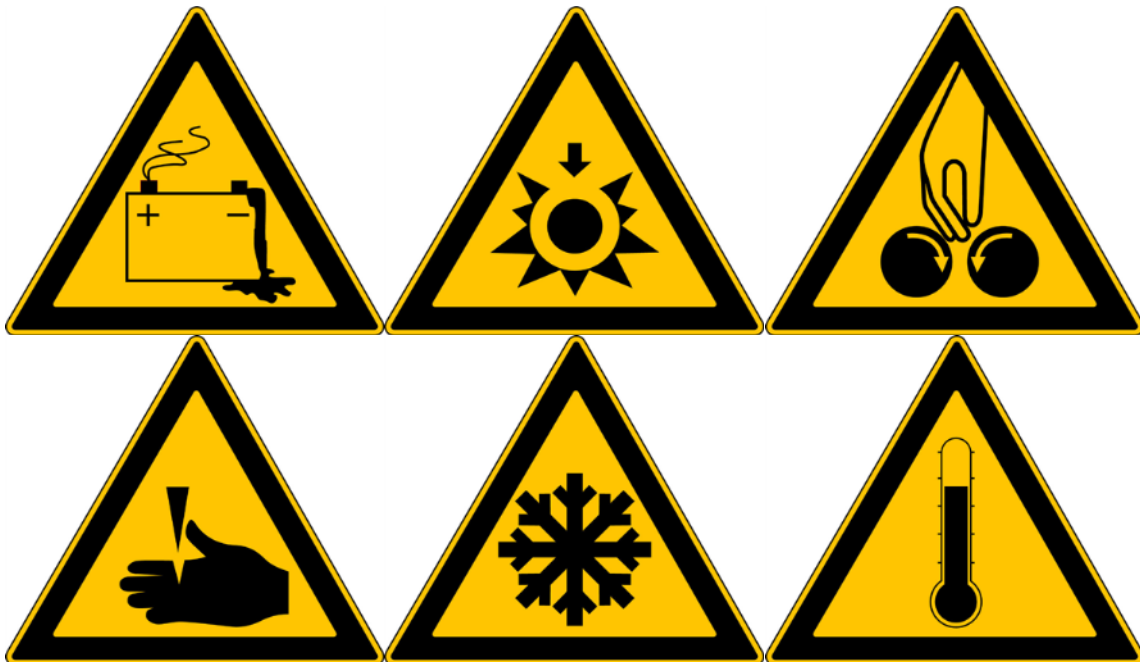

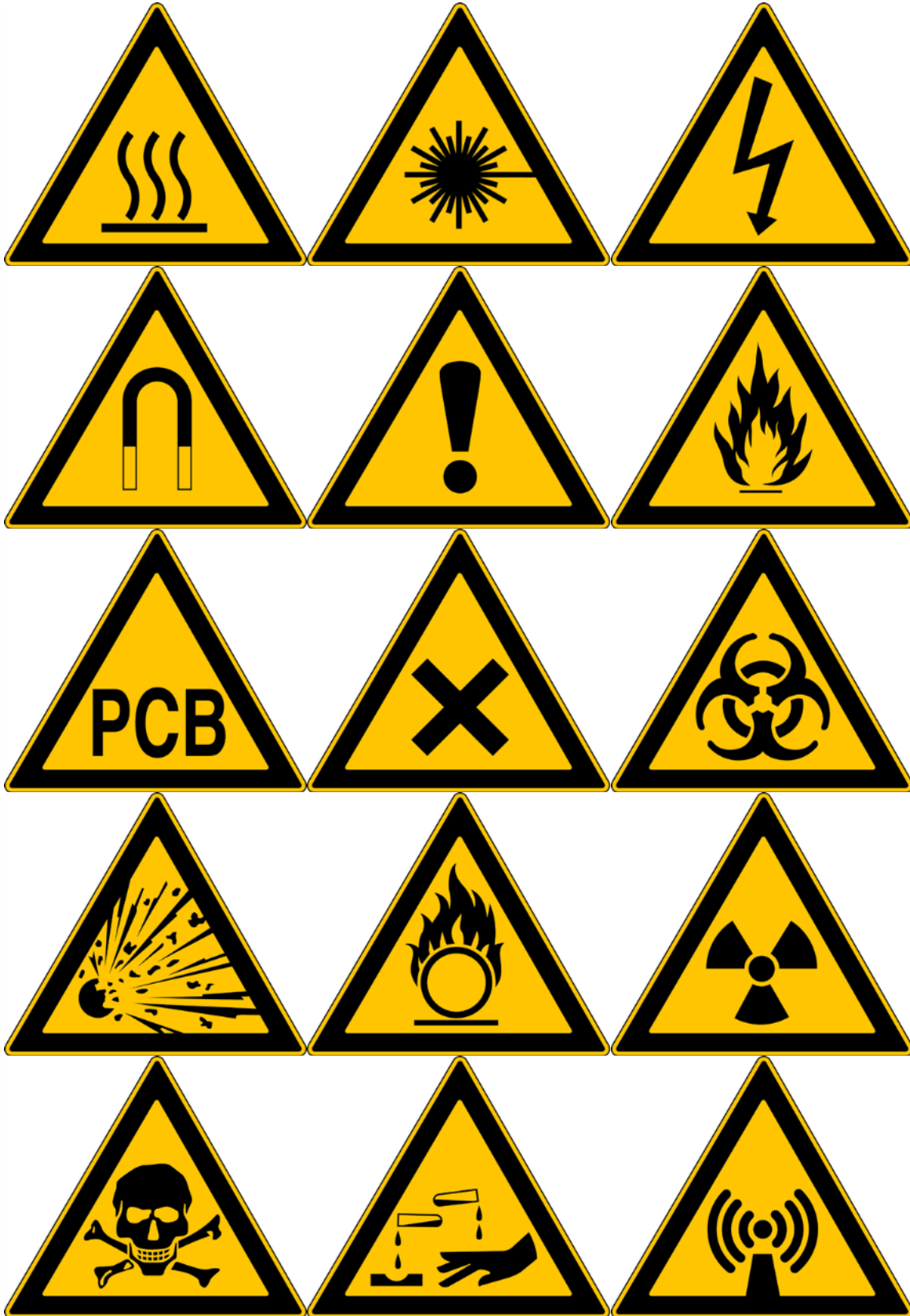

Appendix: Payload-carrying gondolas available

The gondolas

These are the main gondolas that CNES can make available to scientists or manufacturers wishing to organise stratospheric balloon flights.

BANA gondola:

At just 1 m x 0.80 m x 1 m, this small 80 kg structure is particularly suitable for technological flights and can carry payloads of up to 170 kg. There are few services possible on this gondola, and there is no pointing system.

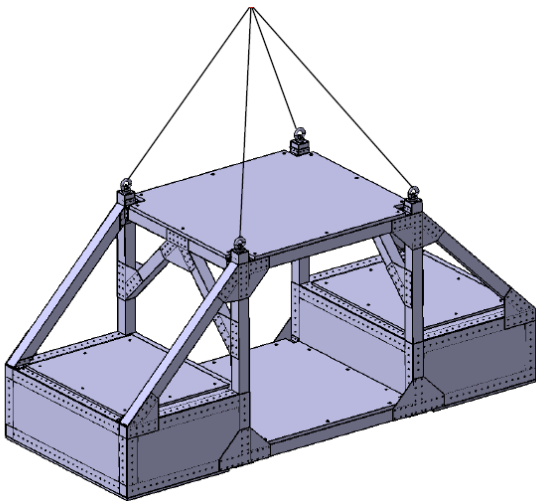

HELIOS gondola:

This gondola built from steel struts and balls can carry equipment on the floor or in the walls of the structure. It weighs 90 kg and can carry payloads of up to 180 kg. It measures 2.06 m x 1.43 m x 1.44 m and is designed for easy integration of medium-sized instruments.

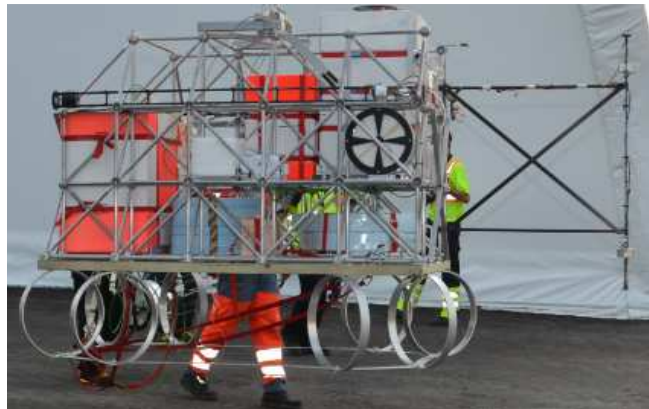
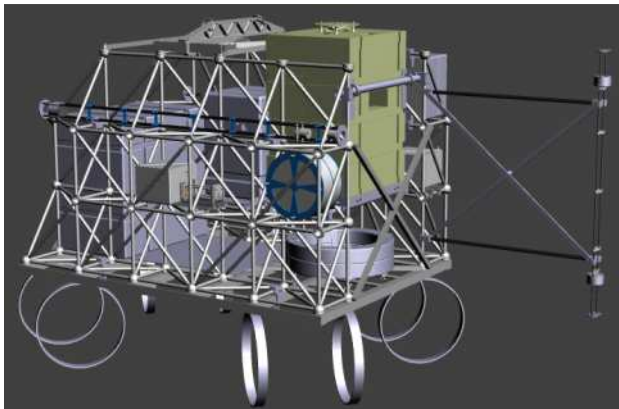

CARMENCITA gondola:

This gondola constructed from struts and balls is currently in the design stage. It will weigh 190 kg and be able to carry payloads of up to 410 kg. It will measure 2.45 m x 1.85 m x 2.20 m and its upper metal beam will be able to include a pivoting and pointing system.

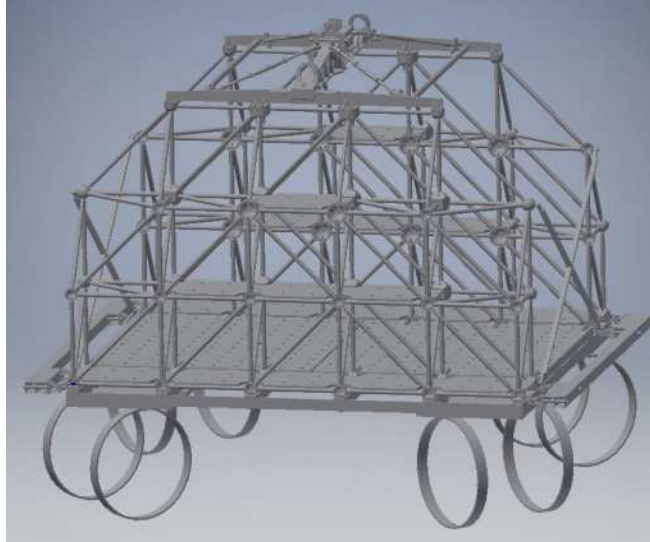

CARMEN gondola:

Suitable for larger payloads (total capacity of 4.7 m³), this structure of struts and balls is particularly appropriate for experiments requiring pointing. With a size of 2.45 m x 1.85 m x 3.0 m and weighing 210 kg on its own, it can carry payloads for a total of 700 kg.

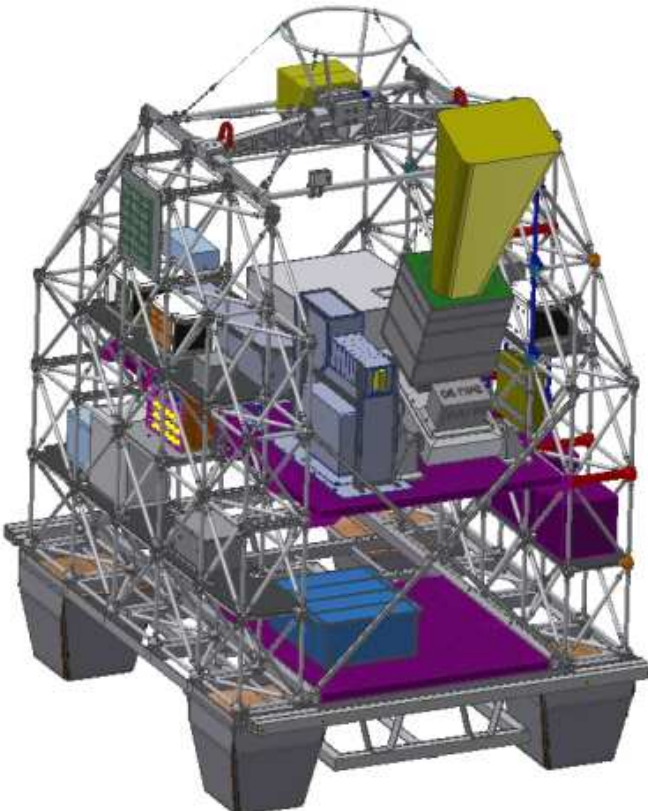

PILOT gondola:

This structure was developed to carry the PILOT telescope. With a size of 2.59 m x 2.1 m x 3.3 m and weighing 250 kg on its own, this gondola can carry payloads for a total of 800 kg and has a complete fine-pointing system that uses the ESTADIUS star sensor.

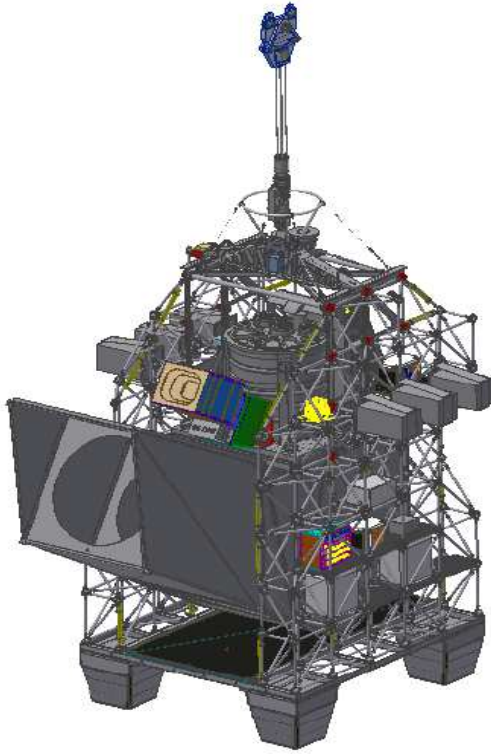

The services

The CARMENCITA, CARMEN and PILOT gondolas are designed to facilitate the provision of services (see diagram below):

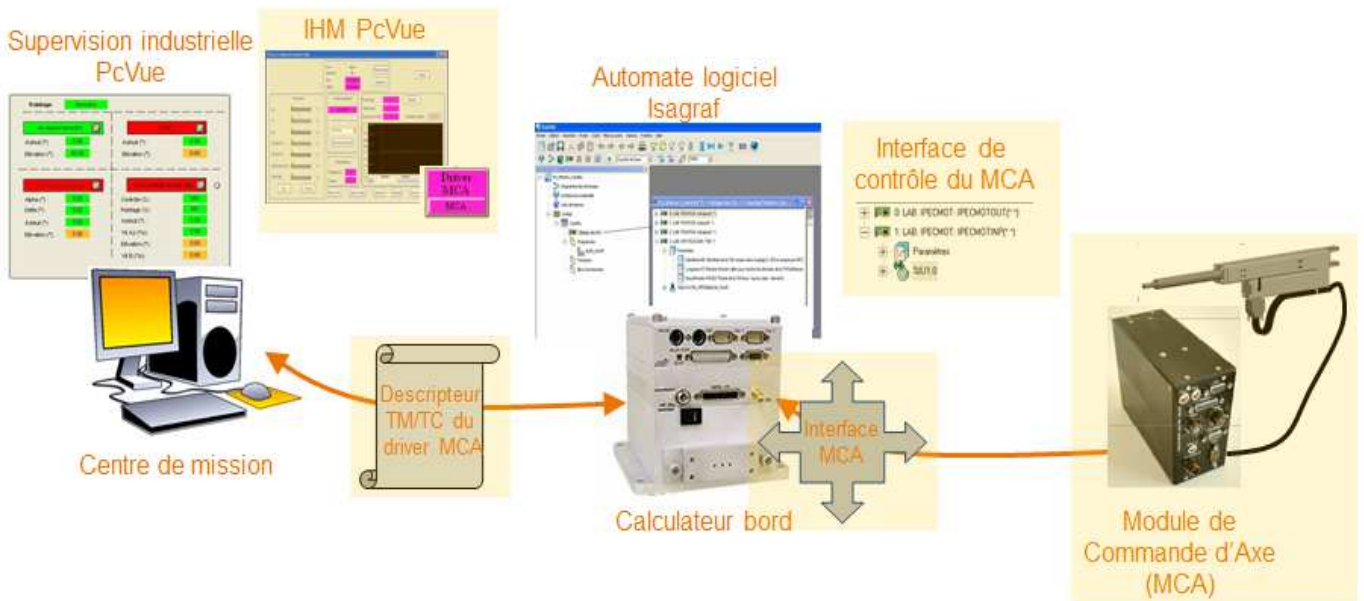

Here are the service platforms proposed:

➤ **Power distribution**

- ❑ Li-Ion batteries [32v - 25V], with 1000W output power
- ❑ Designed to withstand the balloon's radiation environment
- ❑ Secure power circuits supplying the payloads



Power distribution

➤ **Temperature controls**

- ❑ Measure temperature using 3-point PT100
- ❑ **Monitoring temperature**
- ❑ Regulating temperature



Axis control unit

➤ **Axis control unit**

- ❑ **Monitor the axis for position, rotation speed, etc.**
- ❑ Securing via end-of-travel stops
- ❑ 200mm and/or 700mm cylinder, rotating plate, etc.
- ❑ **Primary elevation pointing of a payload (≈10')**
- ❑ **Opening/closing of doors, hatches, etc.**
- ❑ **Rotation to maintain the same view of the sky**



Attitude control unit

➤ **Sensors**

- ❑ **Fibre optic IMU90** Inertial Measurement Unit
- ❑ **μASC DTU** (X/Y = 5", Z = 15", F = 4Hz)
- ❑ **Estadius** (Daytime, X/Y = 1", Z = 10", F = 30Hz)



Estadius and the μASC DTU

➤ **Azimuth pointing**

- ❑ **Orientation and stabilisation of the gondola in azimuth**
- ❑ Pivot with torque meter, gyrometer and magnetometer
- ❑ **Stability: ≈ 1'**



Azimuth pointing module

➤ **Fine pointing**

- ❑ **Orientation and stabilisation of the payload in two degrees of freedom**
- ❑ Stabilisation of the gondola in roll and pitch
- ❑ Fine-pointing actuators, reaction wheels, gyrometer
- ❑ Fine-pointing sensor (Estadius/payload)
- ❑ **Pointing accuracy: < 1"**

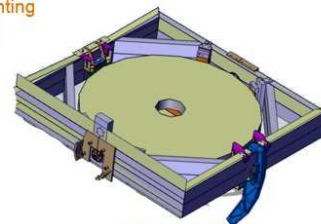

Fine-pointing frame

➤ **Mission preparation**

- ❑ **Implementation of mission-specific aspects** (algorithms, automation, HMIs, etc.)
- ❑ Broadcasting of the date, hour and location
- ❑ Management of inertial pointing, solar pointing
- ❑ Remote attitude control for the instrument
- ❑ ...



Mission control centre



On-board computer

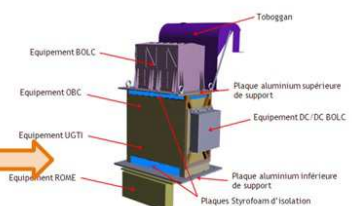

Payload computer

➤ Support for mission definition

- ❑ Mechanical and thermal environments
- ❑ Safety constraints
- ❑ Feasibility, general versus specific outcomes

➤ Development, integration and qualification

- ❑ Mission development for the gondola aspect
- ❑ Support for payload integration and testing
- ❑ Qualification of the integrated gondola and its performance
- ❑ Certification of the integrated gondola

➤ Logistics

- ❑ Container equipped with a suspended floor
- ❑ Logistics Manager with support from DNO/ET/LO

➤ Operations and recovery

- ❑ Participation in preparation and execution of the flight
- ❑ Participation in recovery of the gondola and in securing critical items



Dust-free room (Lagrange North)



Formal acceptance of the Fireball container (20/01/2016)

➤ Sharing our industrial partnerships

- ❑ Mechanical, electronic and IT fields
- ❑ Knowledge of the balloon environment
- ❑ Highly adaptable
- ❑ Rapid response capacity



Solar Cells Control Unit (SCCU)



Array of solar cells

➤ Provision of reusable general-purpose elements

- ❑ e.g.: Generic hardware/software ARM7 core
 - Configuration of equipment and software
 - Management of a parameter database
 - Interoperability of the module (Web Server, TCP communication, etc.)
 - Synchronisation of on-board clock
 - Regulating temperature for each module
 - Execution framework for high and low frequency processing

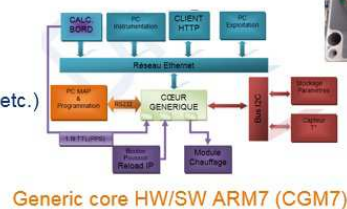

Generic core HW/SW ARM7 (CGM7)



SCCU based on the CGM7

➤ Support for tests

- ❑ Support for final adjustments and payload-oriented tests
- ❑ Provision of training to make the payload teams capable of operating the gondola's sub-systems without other assistance (e.g. power distribution)